



## WARNING

- ⓘ Per una corretta installazione, seguire attentamente le seguenti istruzioni.
- Ⓔ Para una instalación correcta, siga cuidadosamente las siguientes instrucciones.
- Ⓓ Für eine korrekte Montage bitte lesen Sie aufmerksam folgende Montageanleitungen.
- ⒼⒷ For the correct installation Please follow the instructions for the correct installation.
- Ⓕ Pour une installation correcte, suivez attentivement les instructions suivantes.
- ⓇⓊⓈ Для правильной установки требуется соблюдать инструкцию.



# TERRICONS



MADE IN ITALY

PAT-PENDING

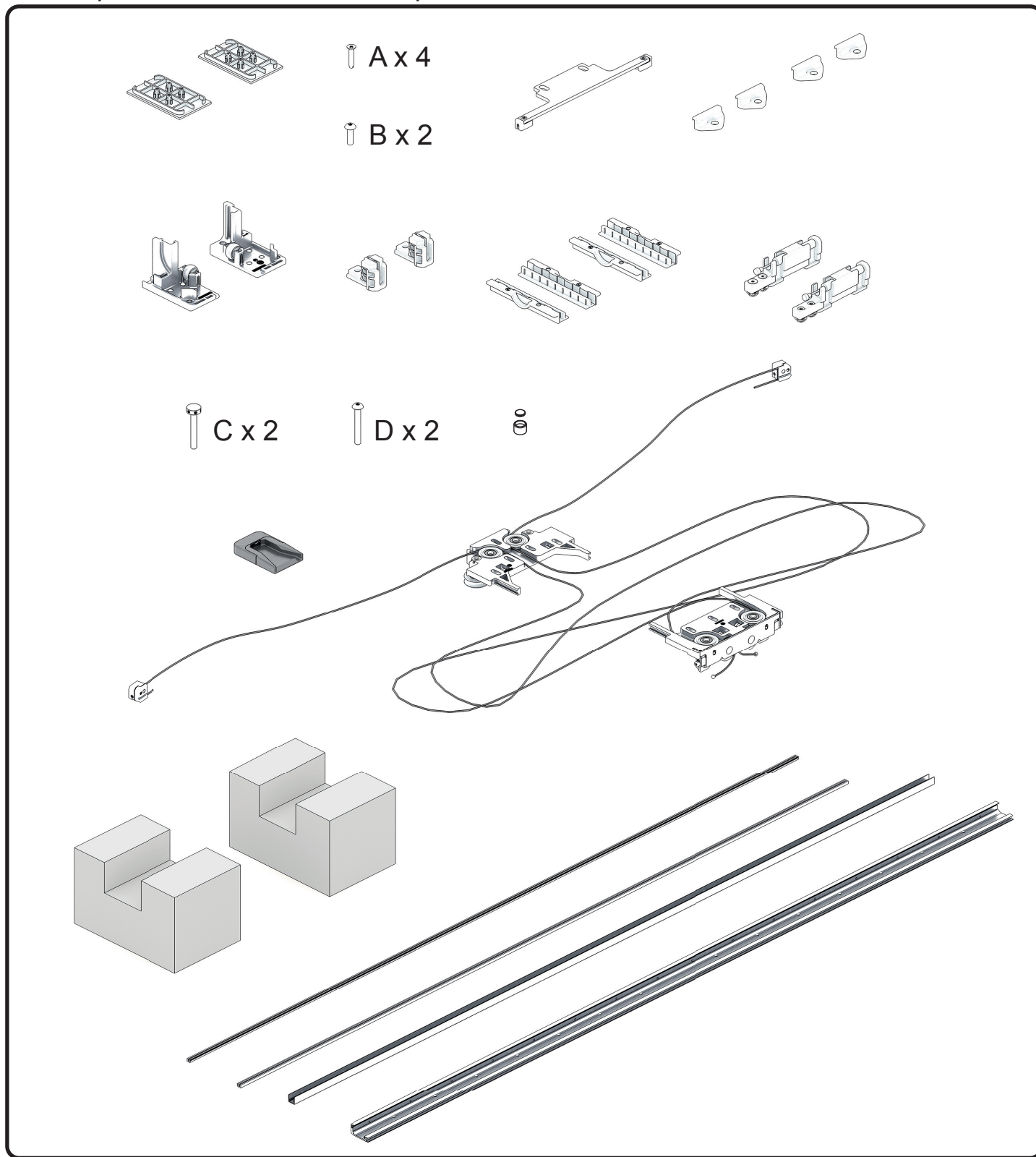
ⓘ Componenti inclusi ⓘ Componentes incluidos ⓘ Mitgelieferte Komponenten  
 ⓘ Components included ⓘ Composants inclus ⓘ Элементы входящие в комплект поставки

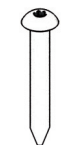

ⓘ Componenti non inclusi ⓘ Componentes no incluidos ⓘ Nicht mitgelieferte Komponenten  
 ⓘ Components not included ⓘ Composants non inclus ⓘ Элементы не входящие в комплектацию

<p><b>*</b></p>  <p>TC 4,5 mm, 16 pcs</p>	<p><b>**</b></p>  <p>TSP 4,5 x max 13 mm, 16 pcs</p>	<p><b>***</b></p>  <p>Ø8 mm, TC 6 mm, 12 pcs</p>
--	---	---



① Preparazione pannello ⑤ Preparación del panel ④ Vorbereitung des Türblatt  
② Door leaf preparation ⑥ Préparation du panneau ③ Подготовка дверного полотна

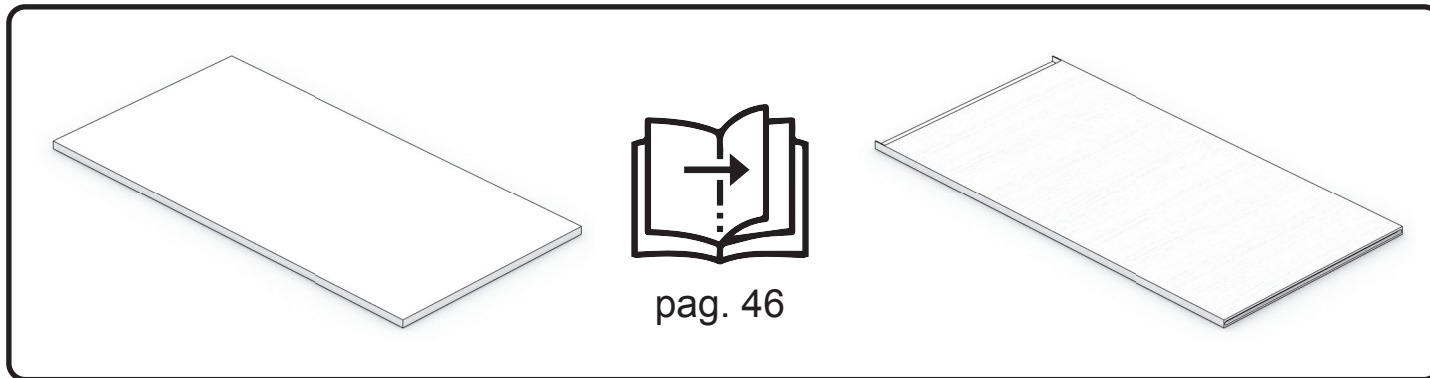

① Preparazione profili ⑤ Preparación del perfil ④ Vorbereitung der Profile  
② Profiles preparation ⑥ Préparation des profils ③ Подготовка профилей

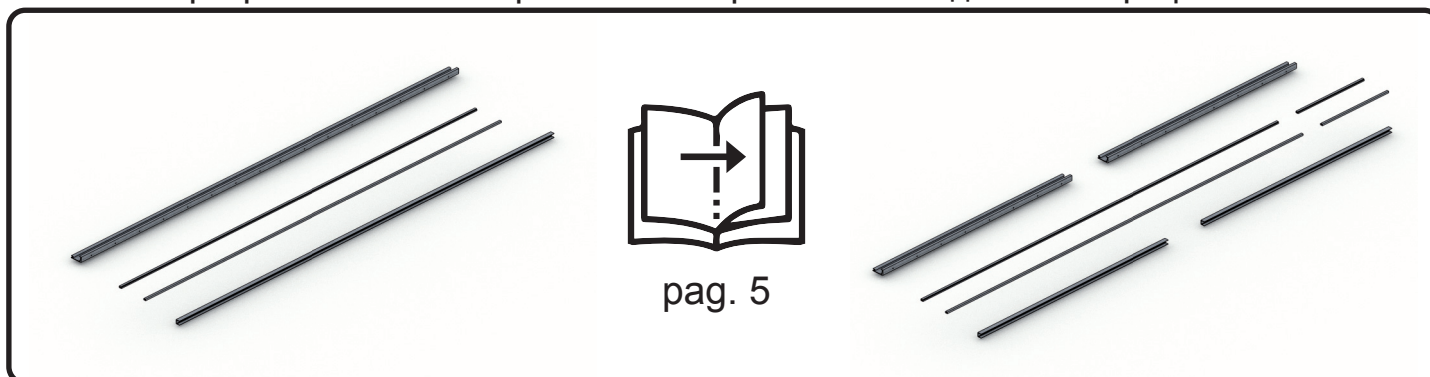

① Utensili per installazione ⑤ Herramientas de instalación ④ Montagewerkzeug  
② Installation utelsils ⑥ Outils necessaires pour l'installation ③ Инструменты для установки

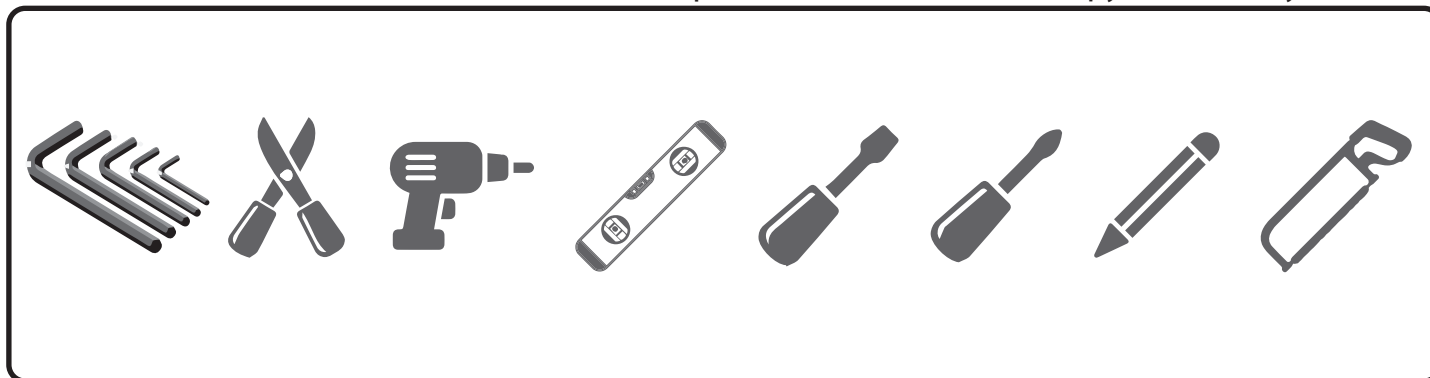

① Domande ⑤ Preguntas ④ Fragen  
② Questions ⑥ Demande ③ Есть вопросы

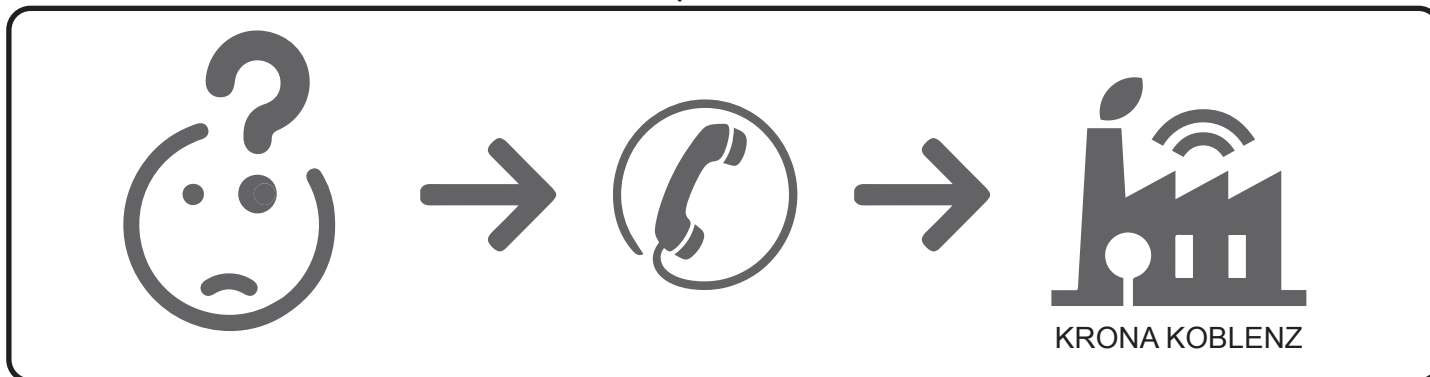



- ① 1. Preparazione profilo superiore
- ② 1. Preparación del perfil superior
- ③ 1. Vorbereitung der oberen Profile
- ④ 1. Upper profile preparation
- ⑤ 1. Préparation du profil supérieur
- ⑥ 1. Подготовка верхнего трека

1.1

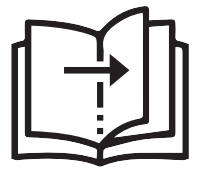
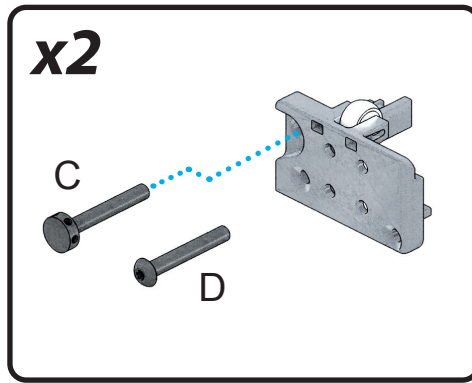
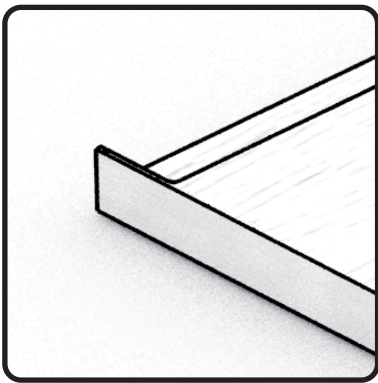
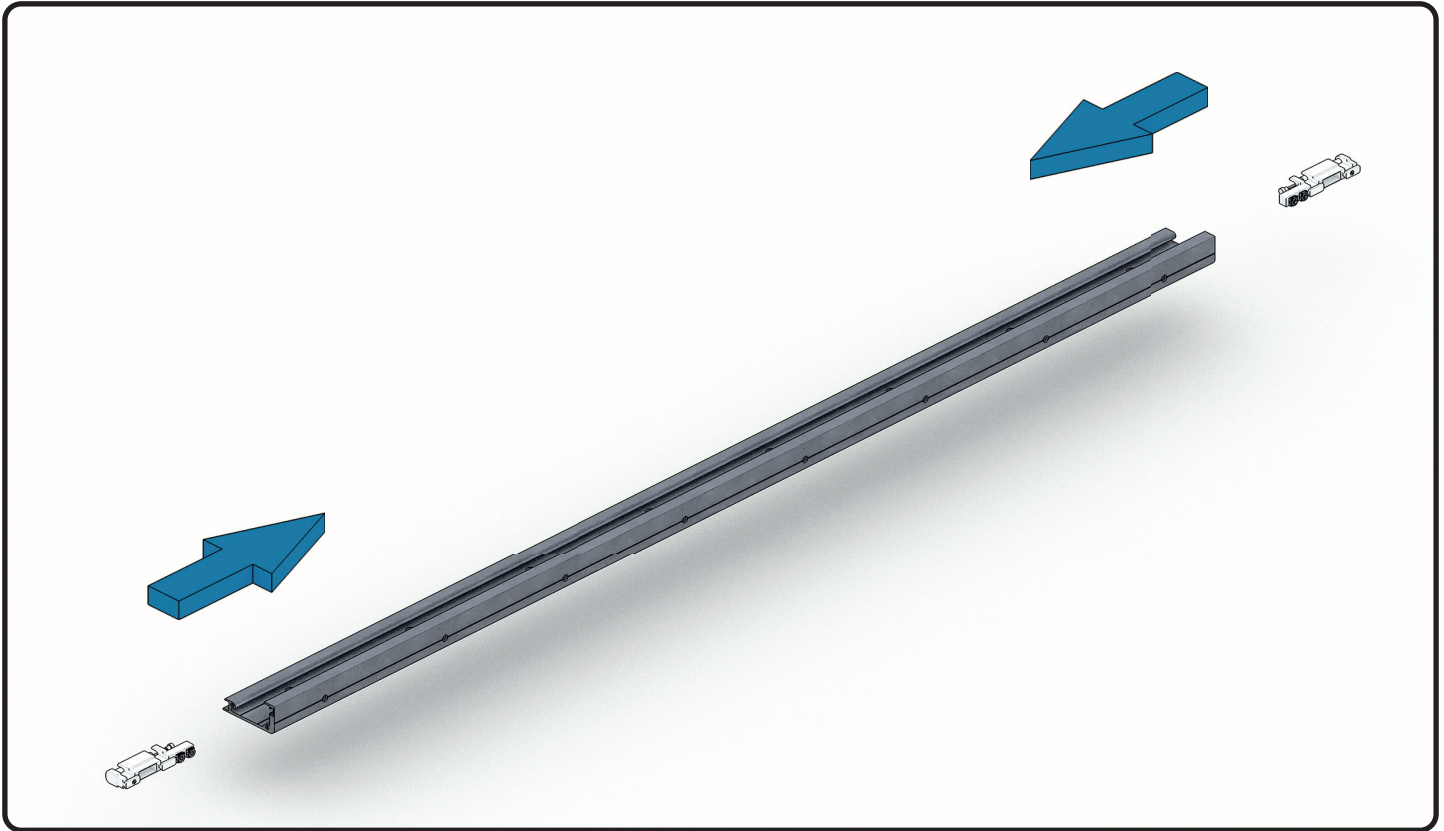

1.2

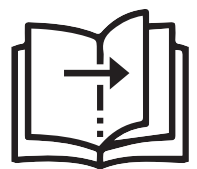
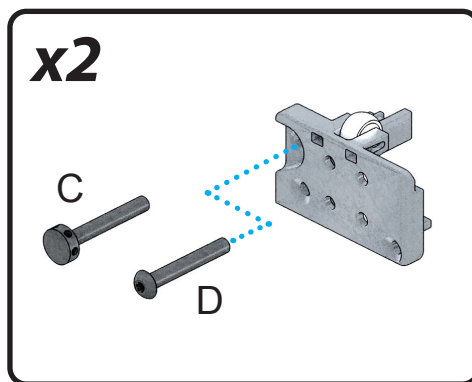
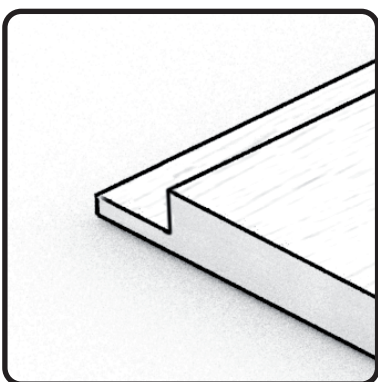

1.8

6



1.2

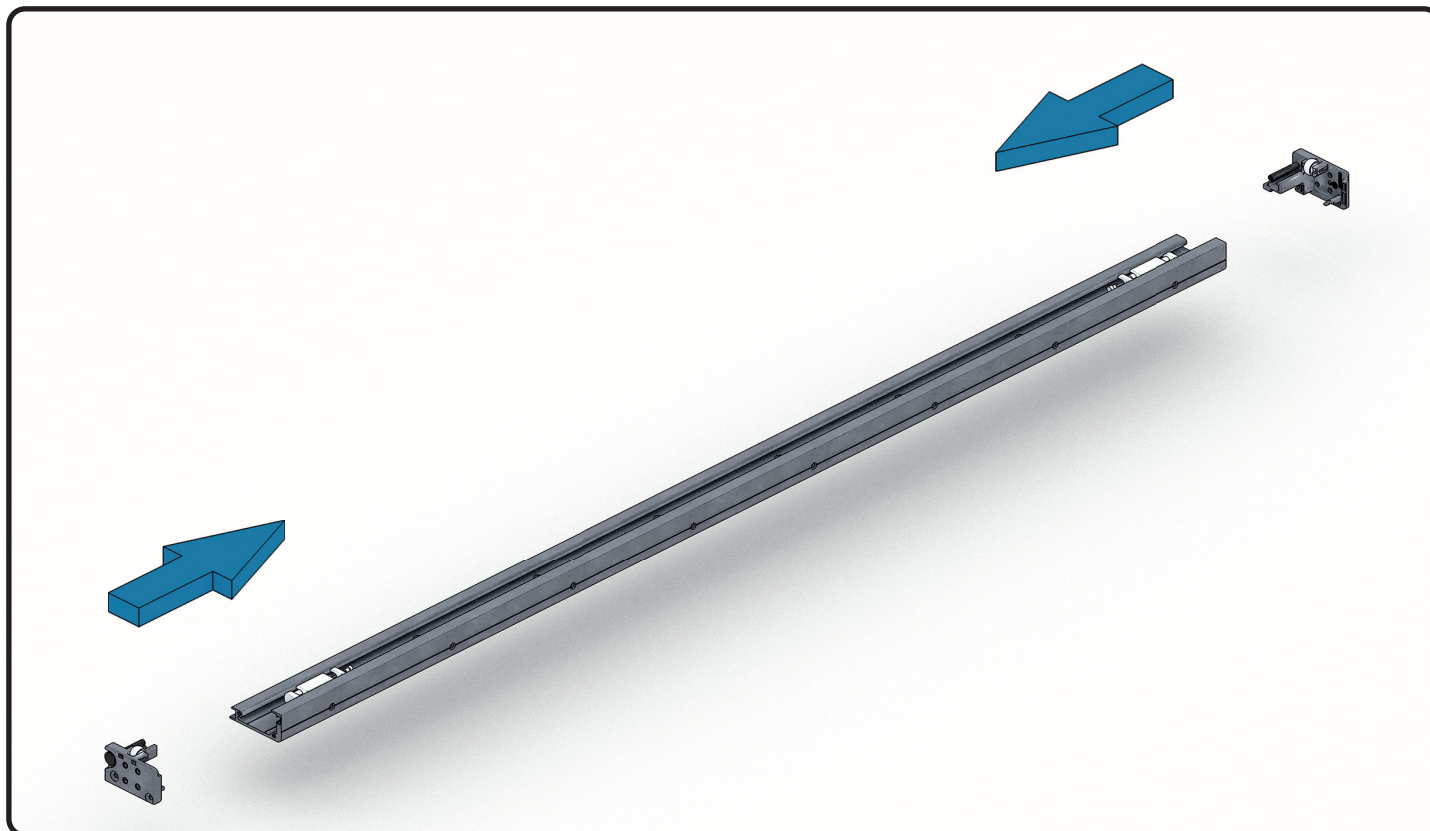

1.3

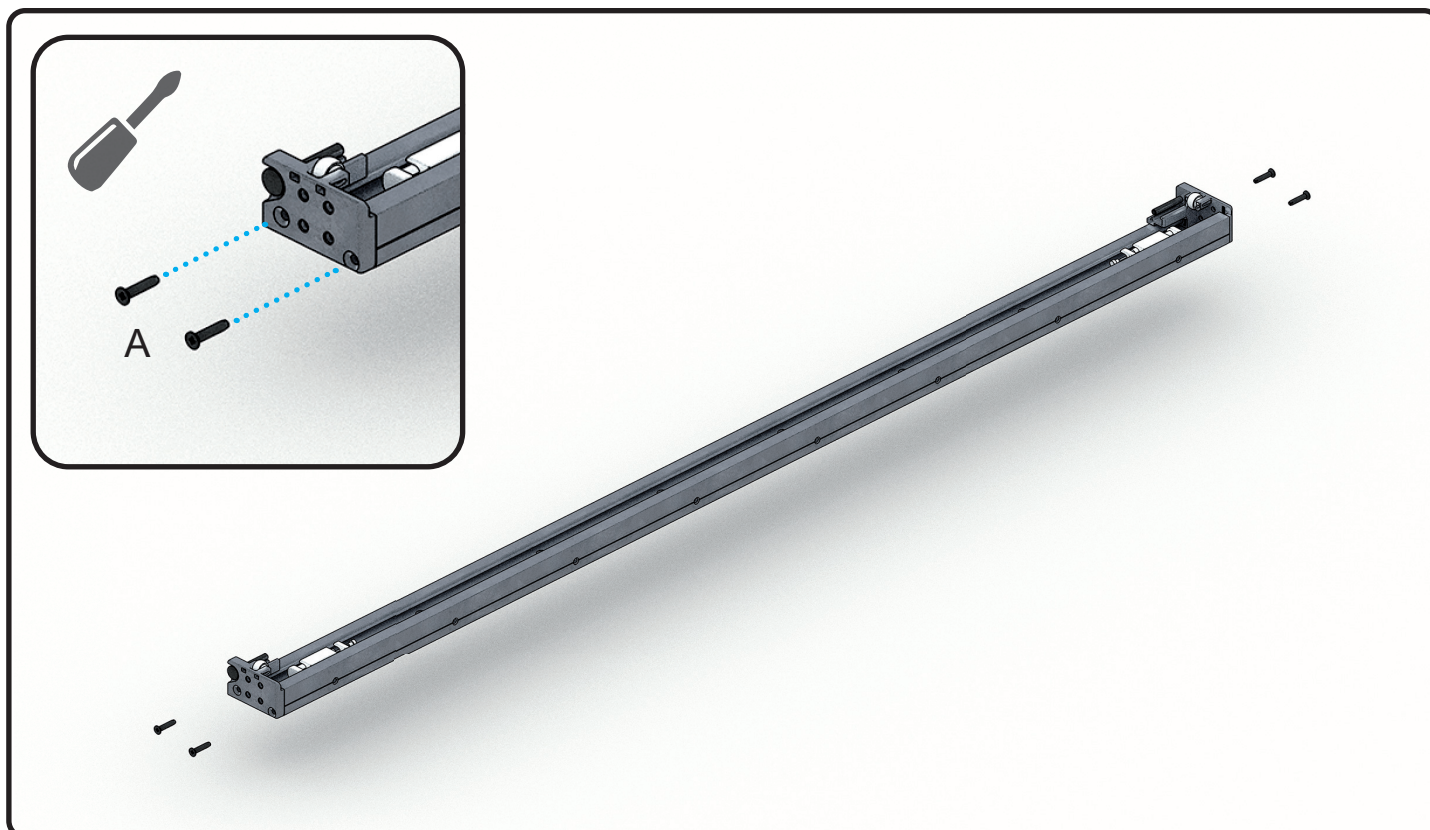

1.4

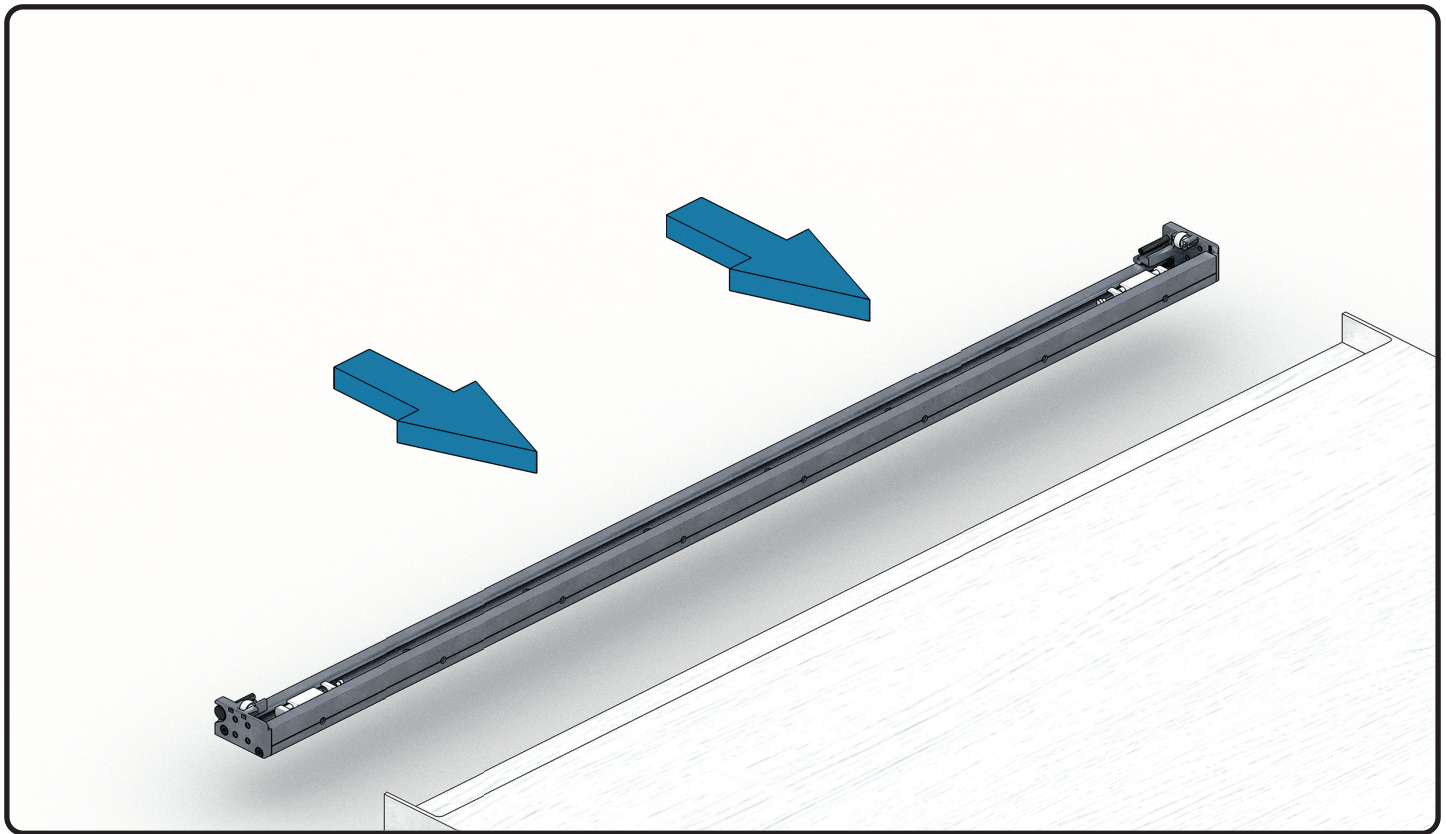

1.5

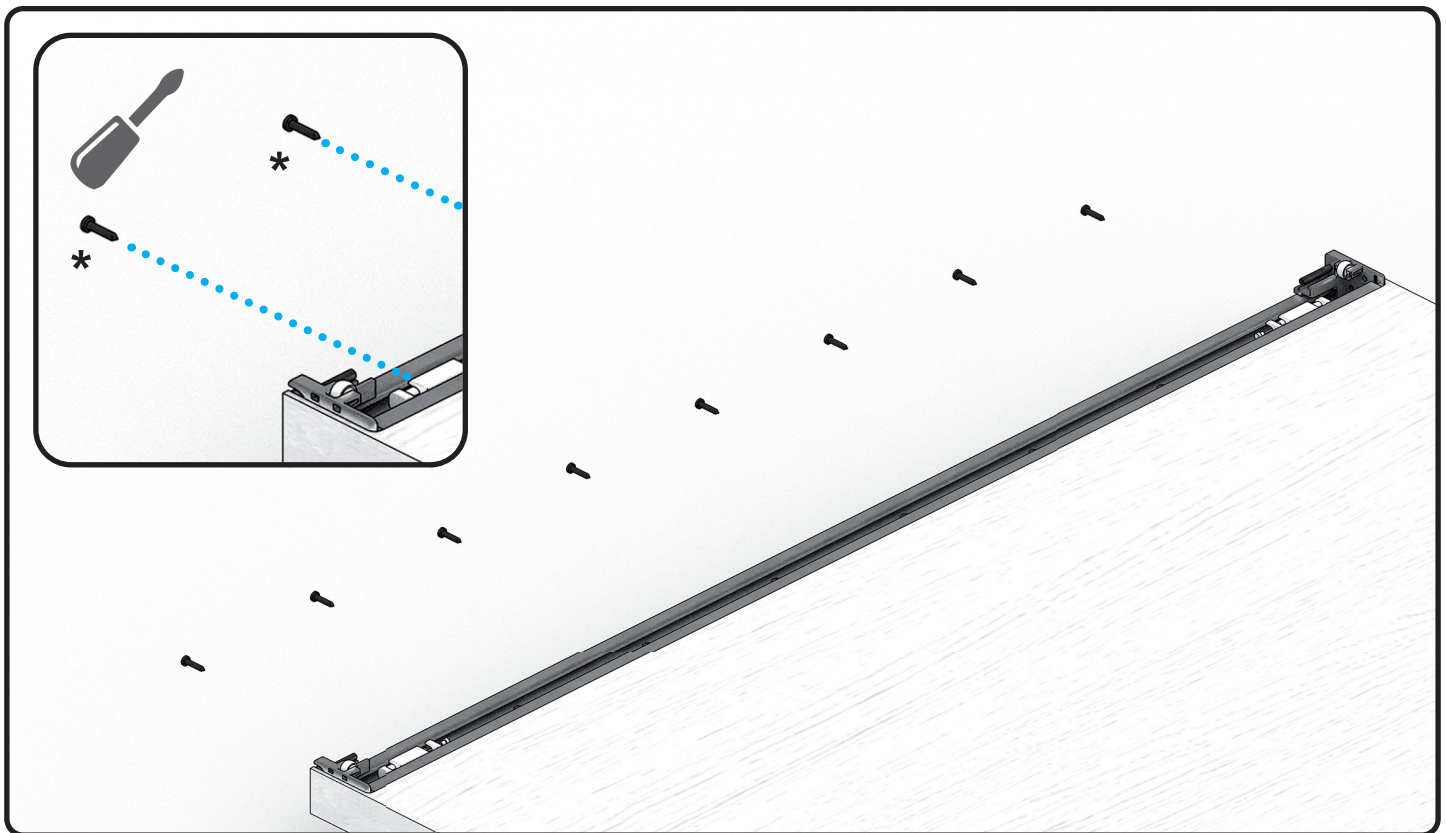



1.6

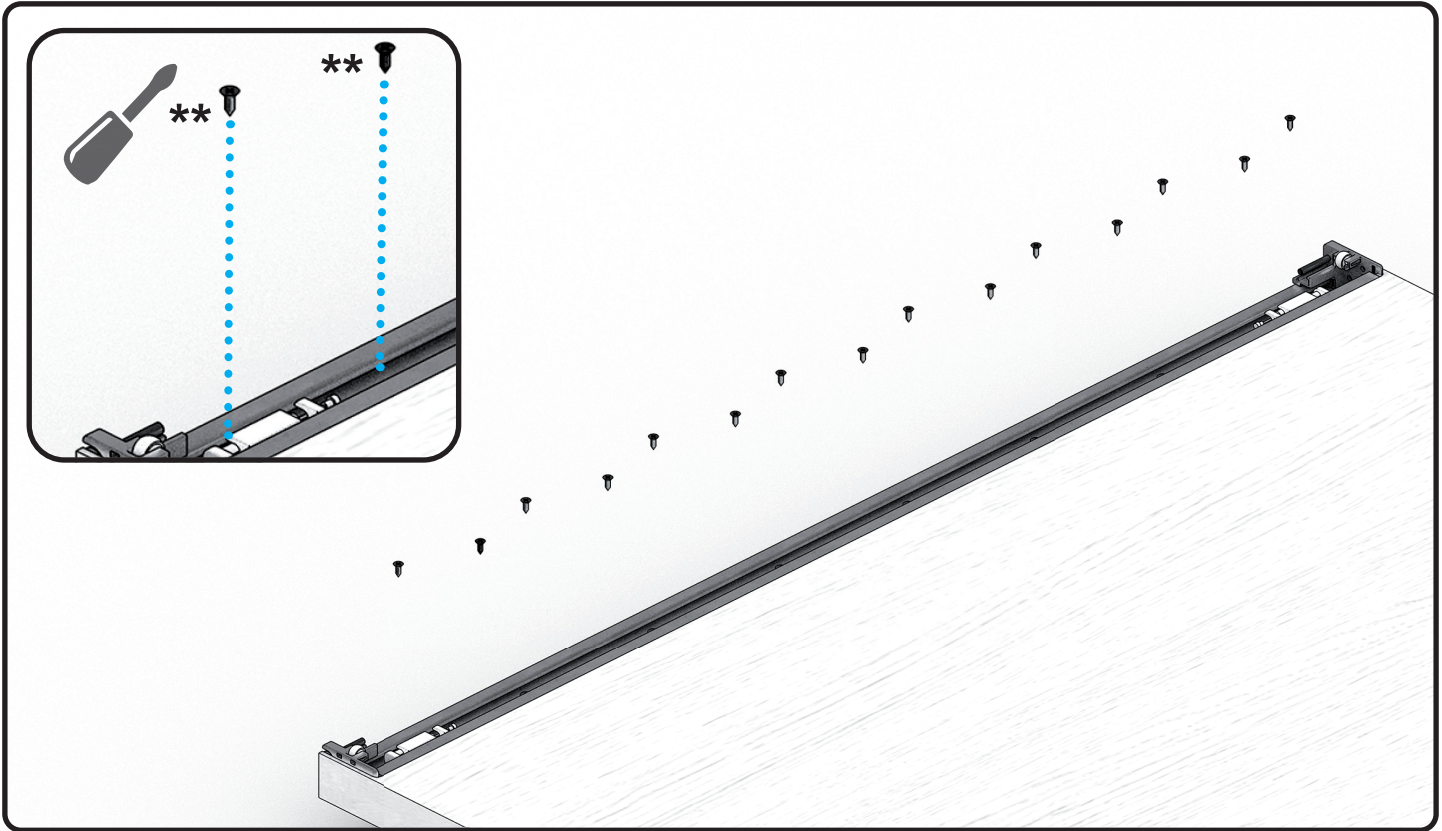

1.7





1.8

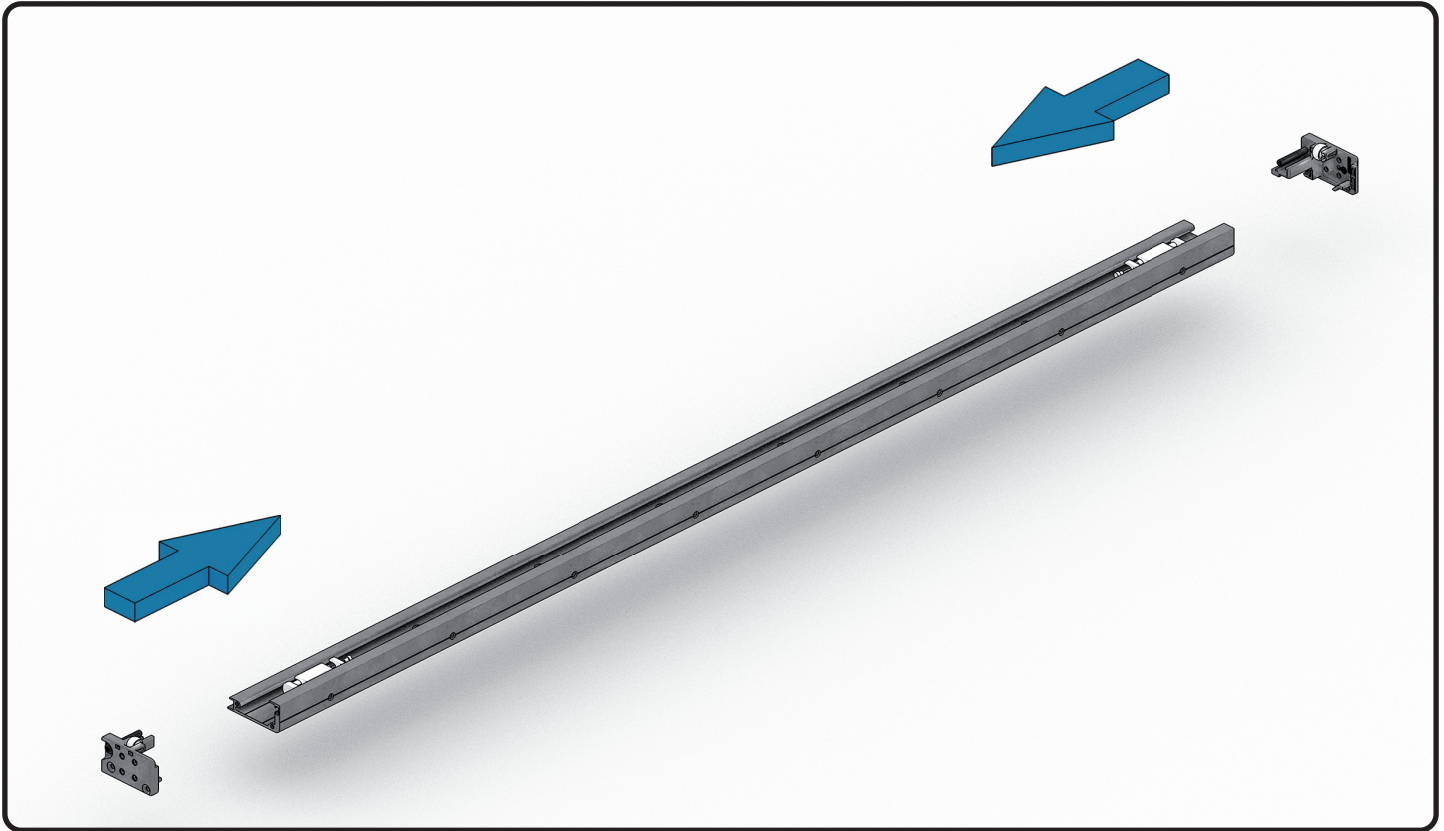

1.9

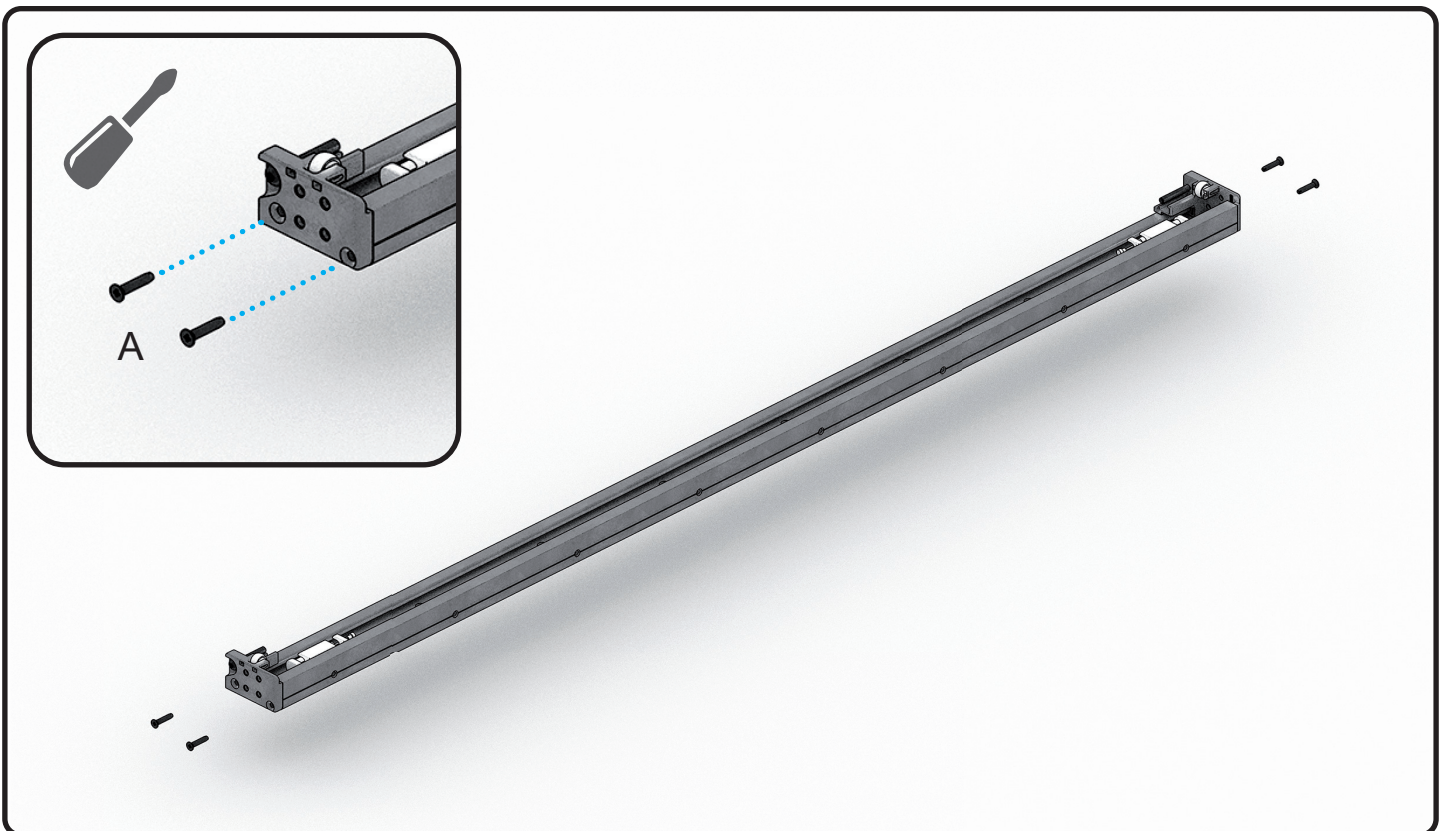

10



1.10

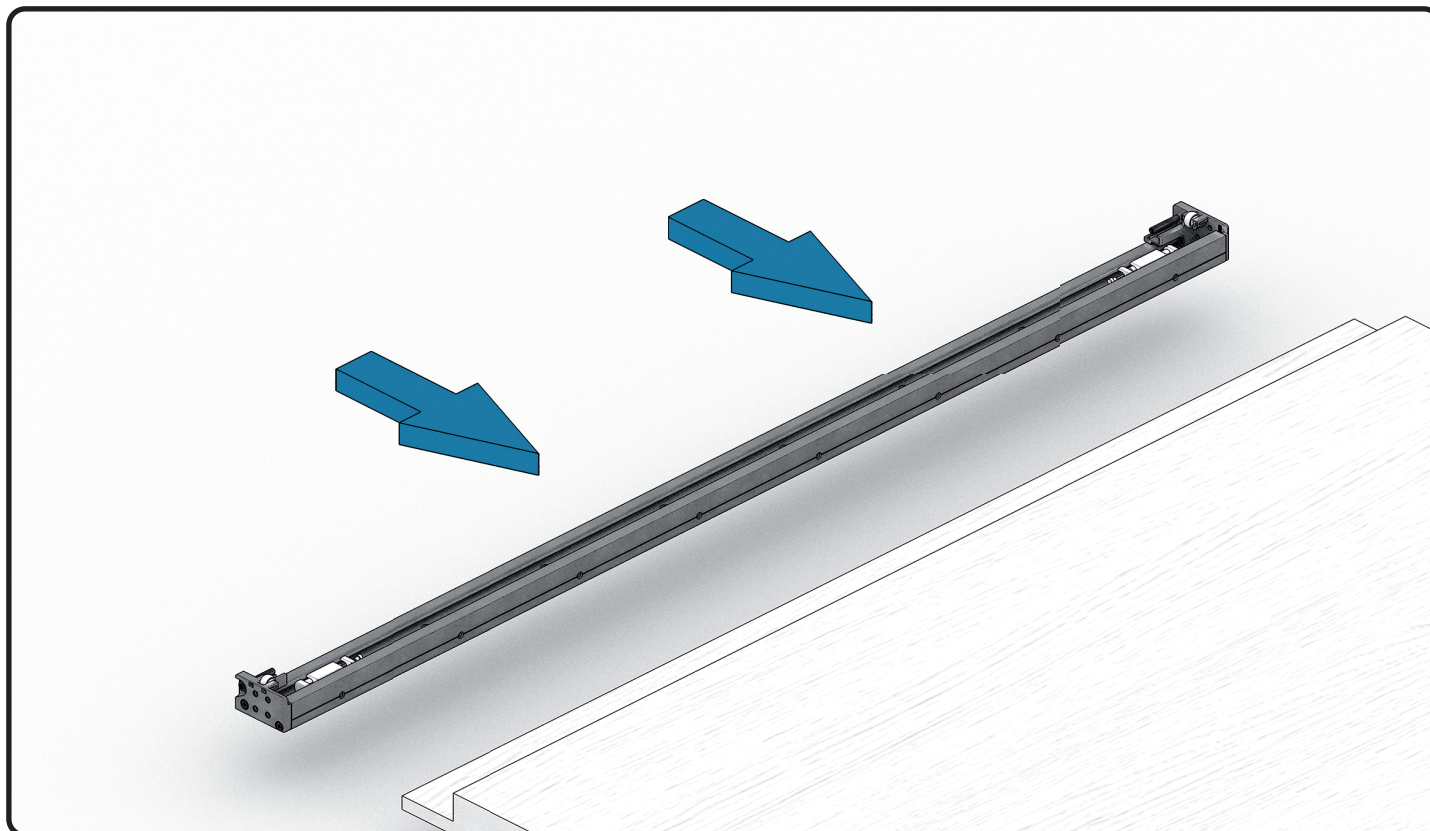

1.11

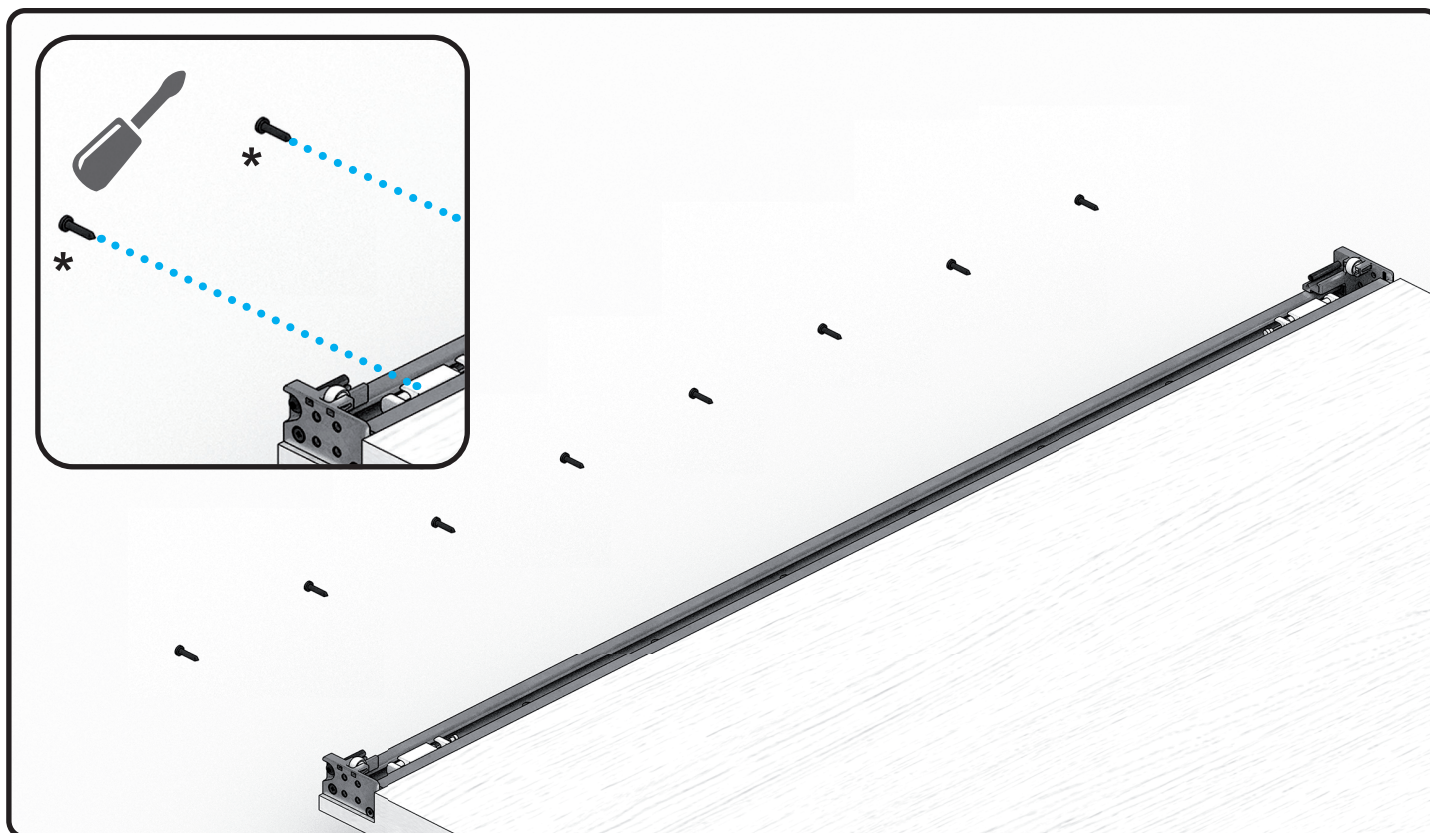



1.12

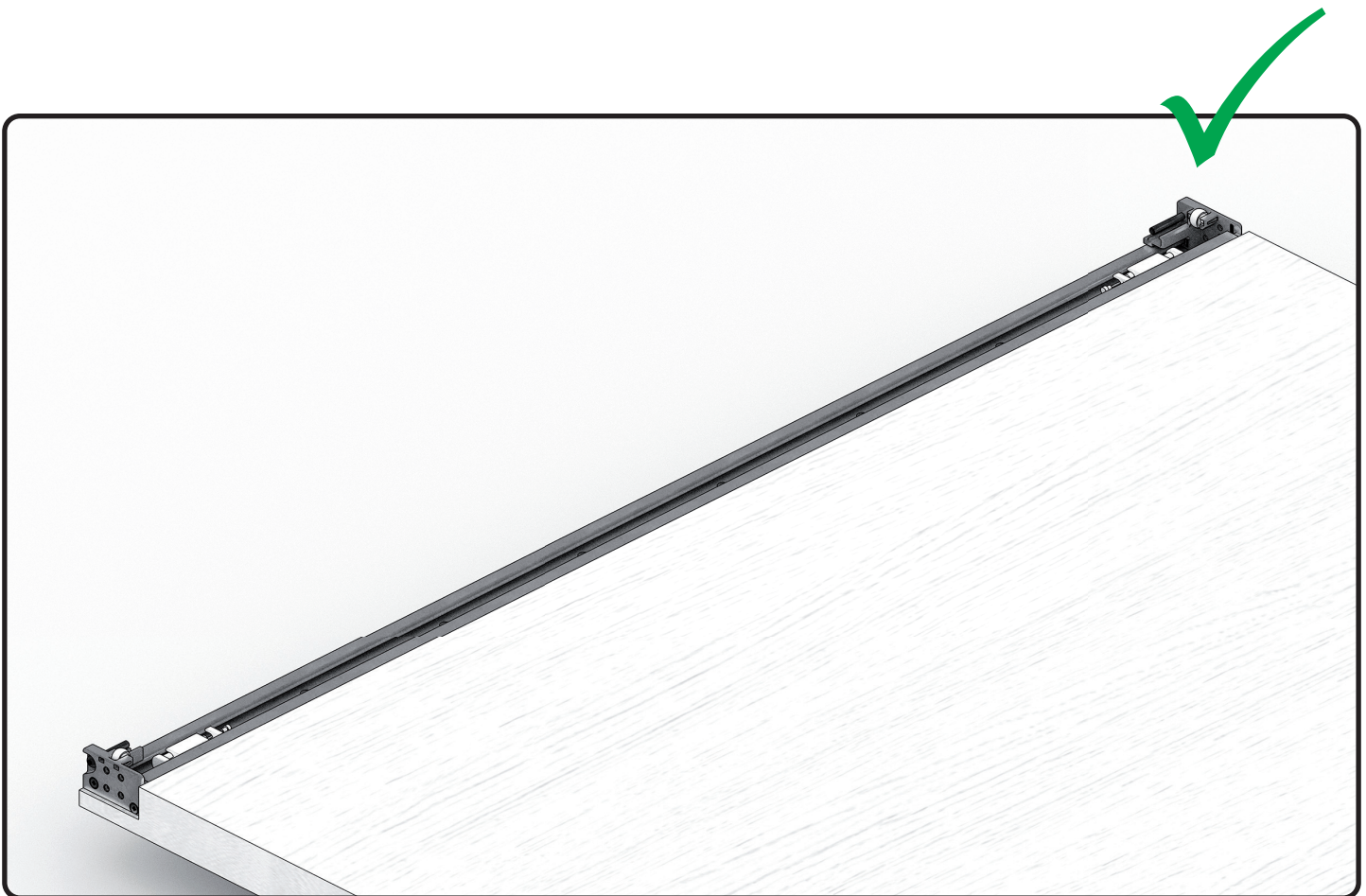
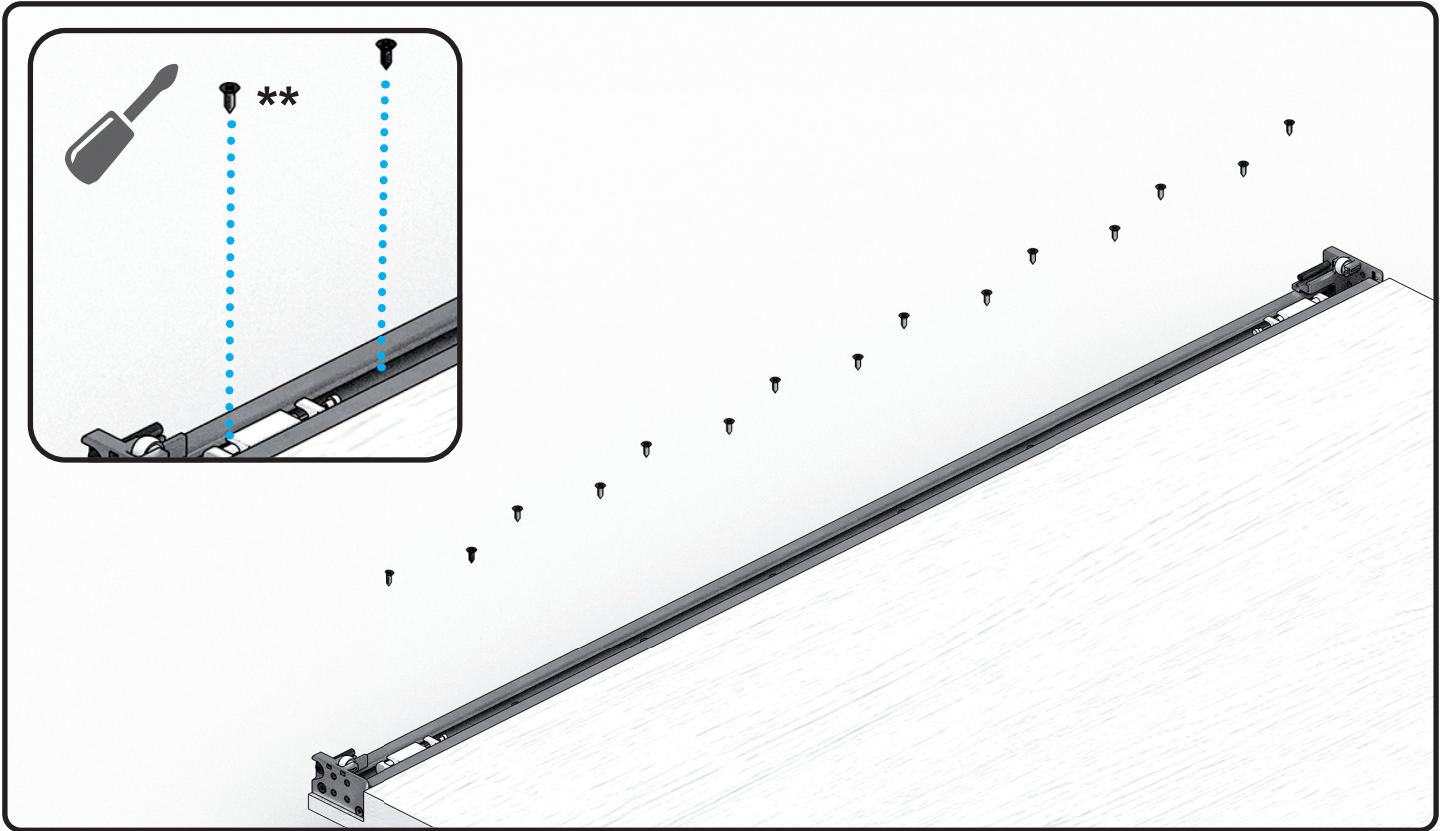

- ① 2. Preparazione profilo inferiore
- ② 2. Preparación de perfil inferior
- ③ 2. Vorbereitung des unteren Profil
- ④ 2. Lower profile preparation
- ⑤ 2. Préparation du profil inférieur
- ⑥ 2. Установка нижней направляющей



2.1

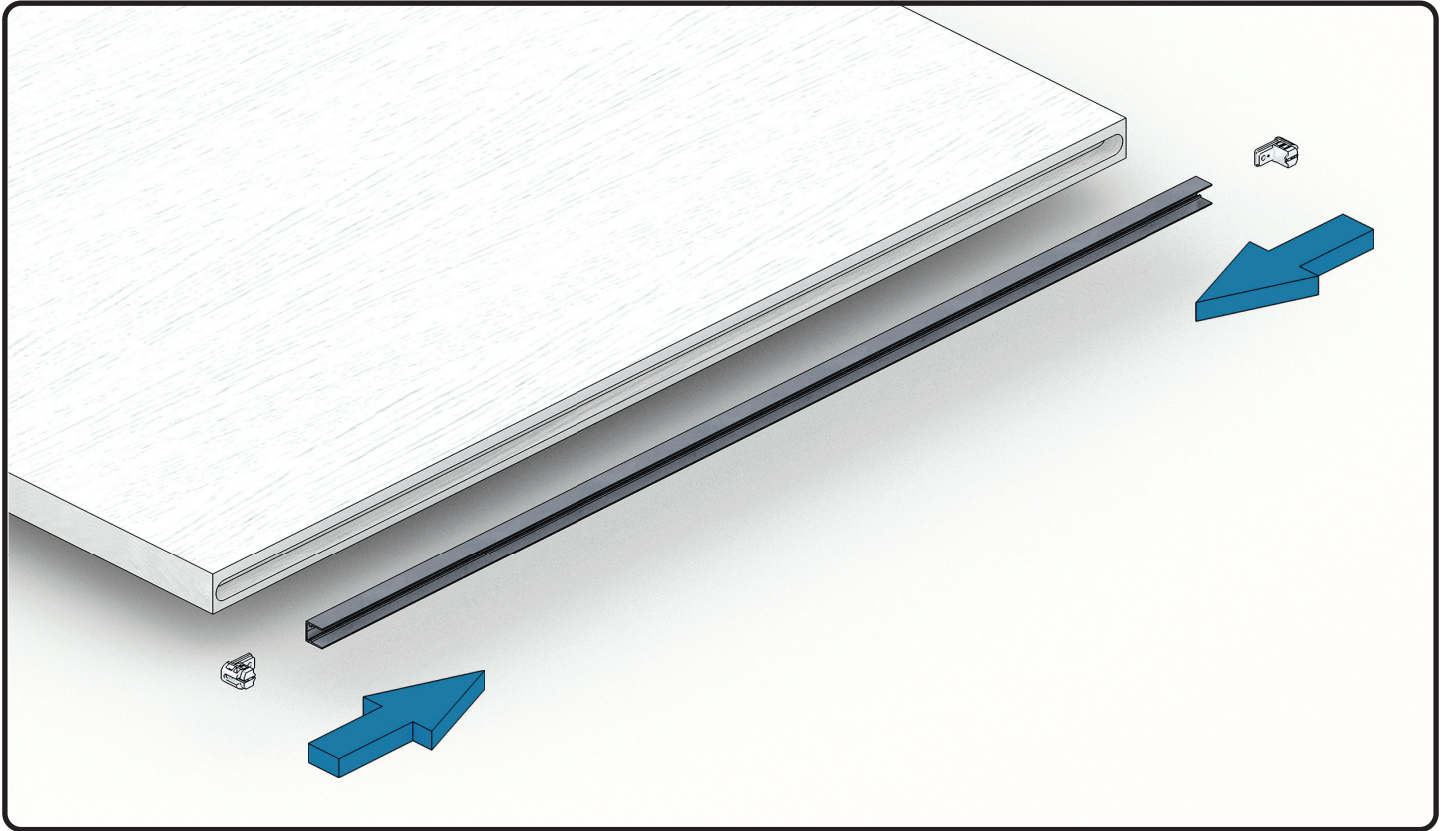

2.2

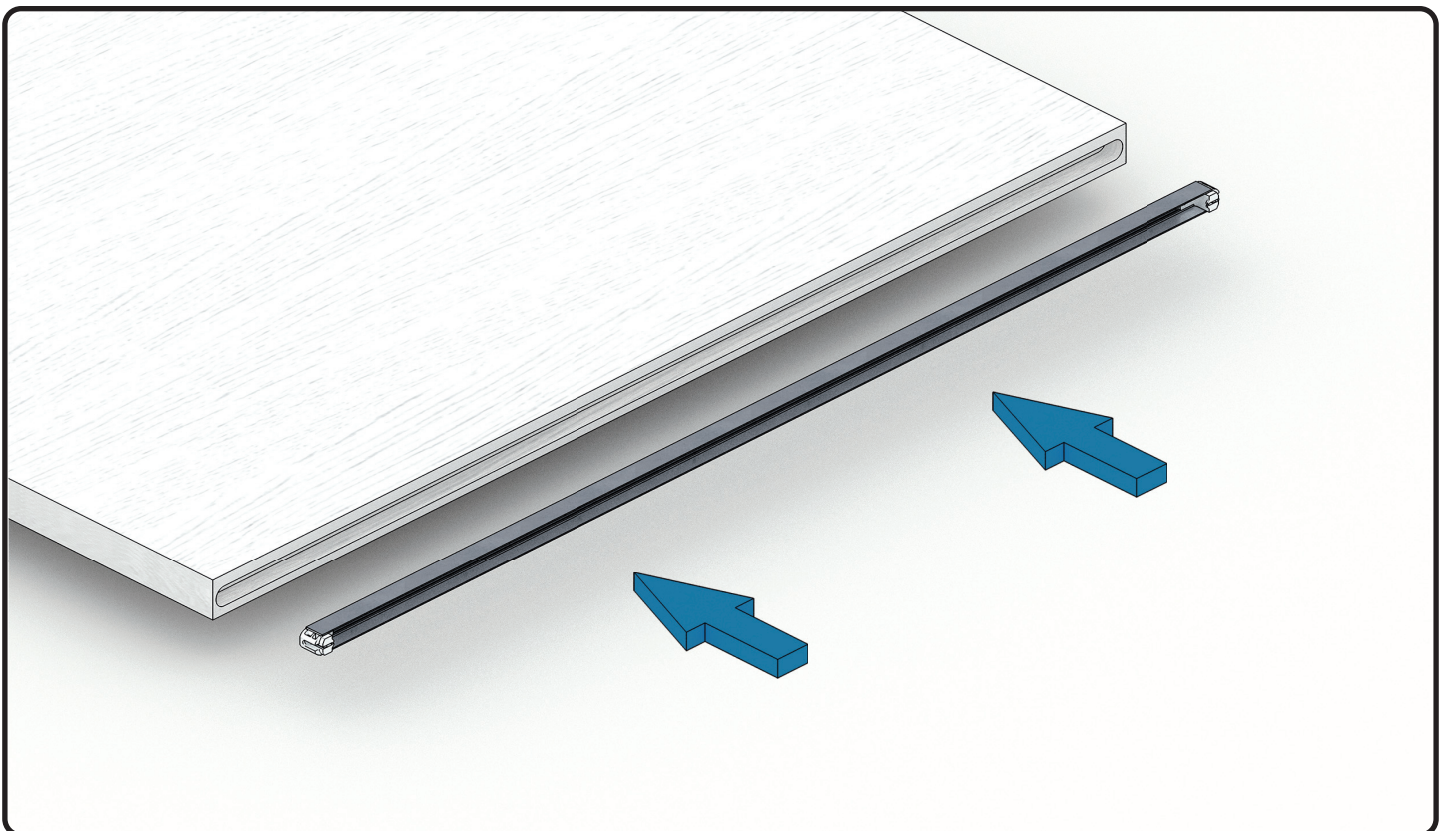



2.2

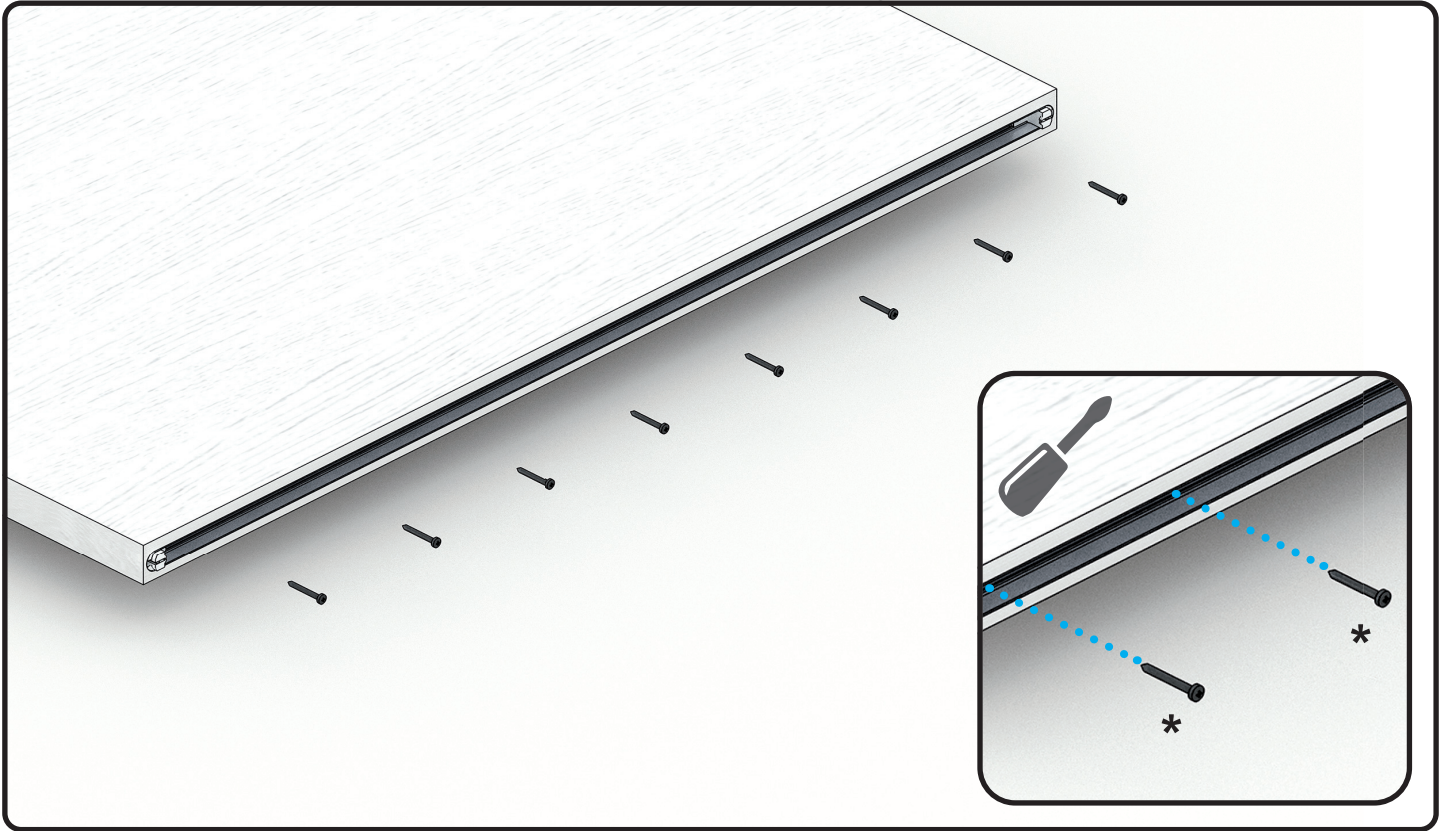





- ① 3. Preparazione telaio
- ② 3. Preparación del marco
- ③ 3. Vorbereitung des Rahmen
- ④ 3. Frame preparation
- ⑤ 3. Préparation du panneau
- ⑥ 3. Подготовка тросовой системы  
и её крепёжной рамы

### 3.1

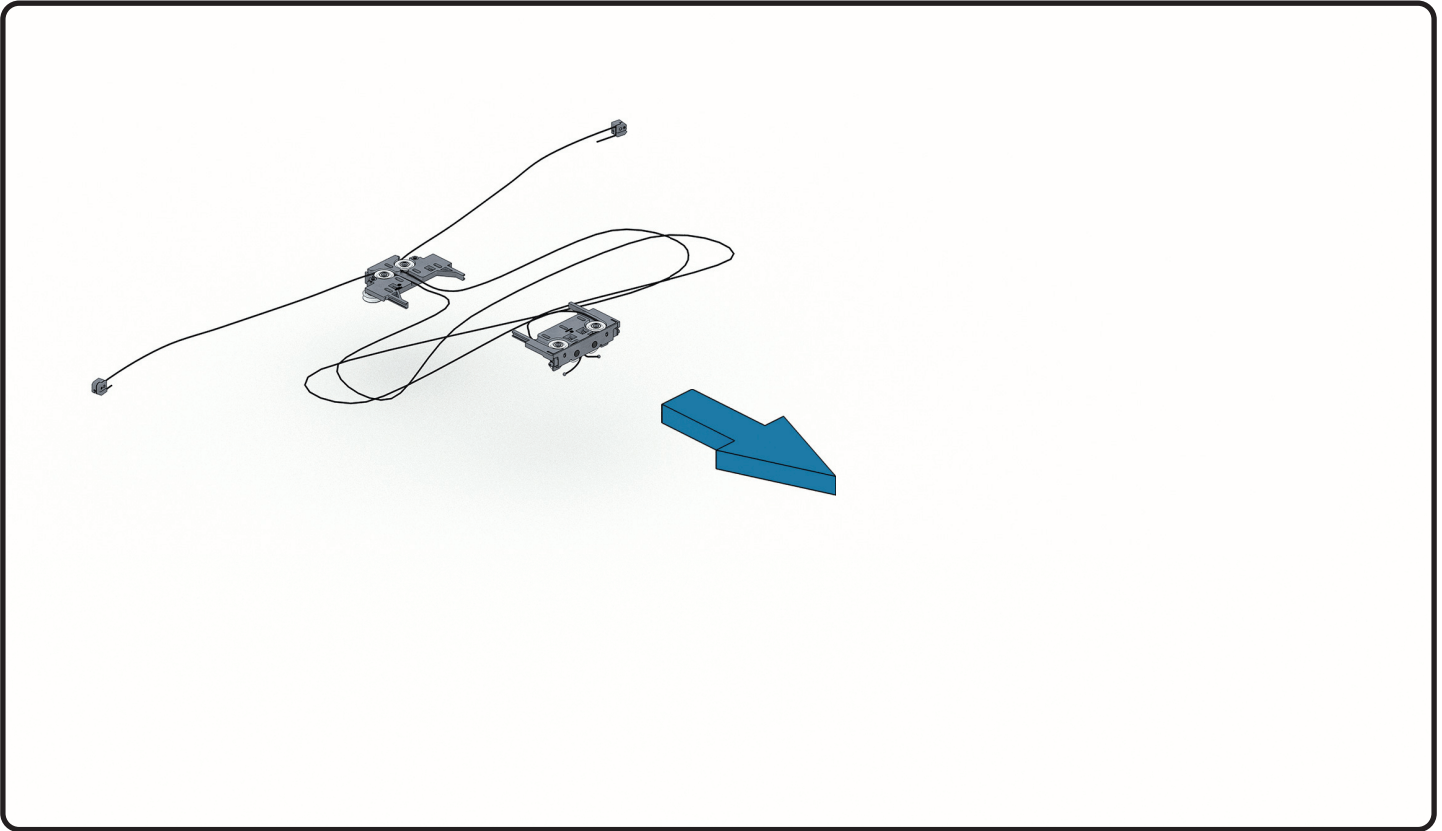

### 3.2

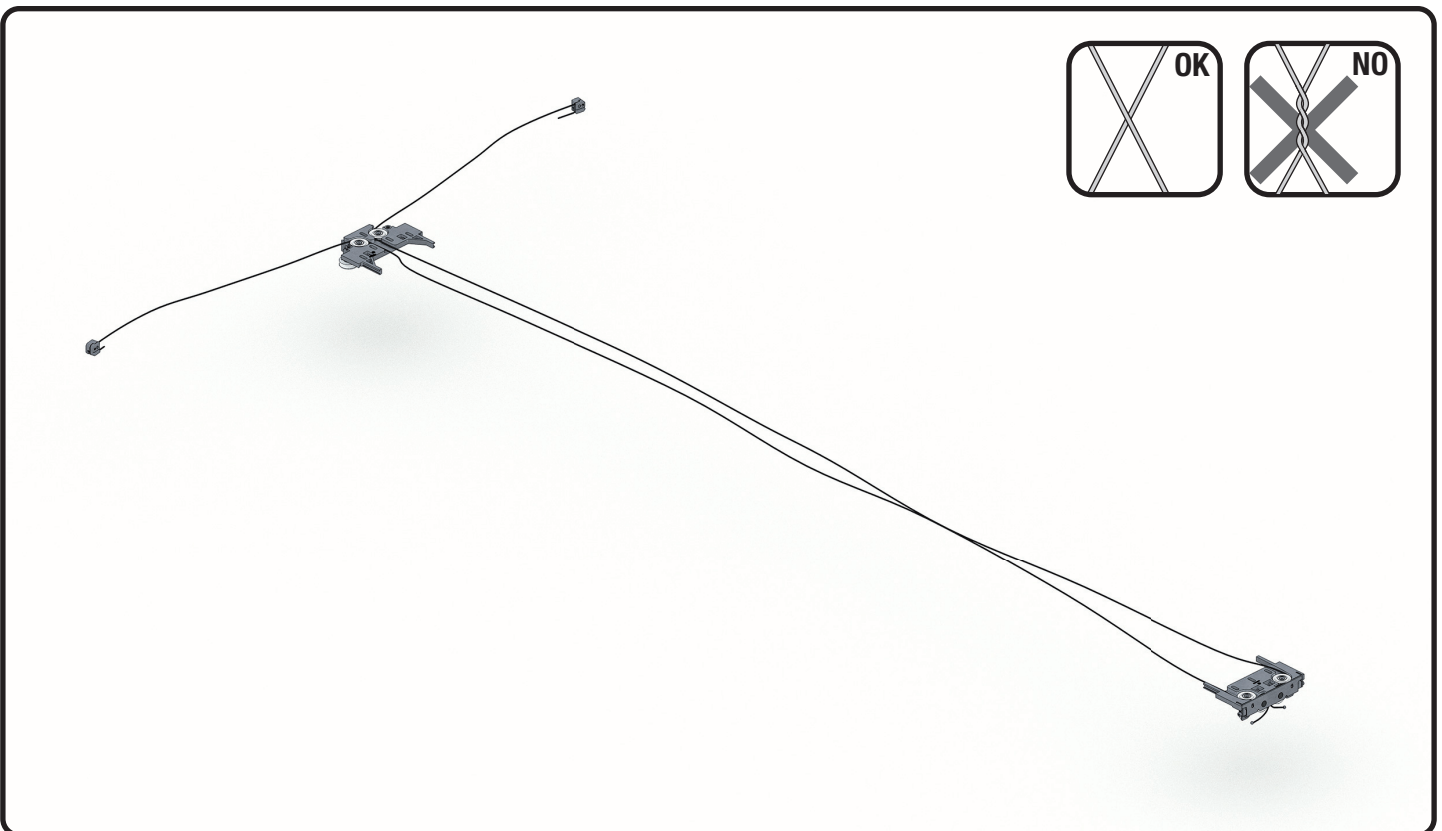

### 3.3

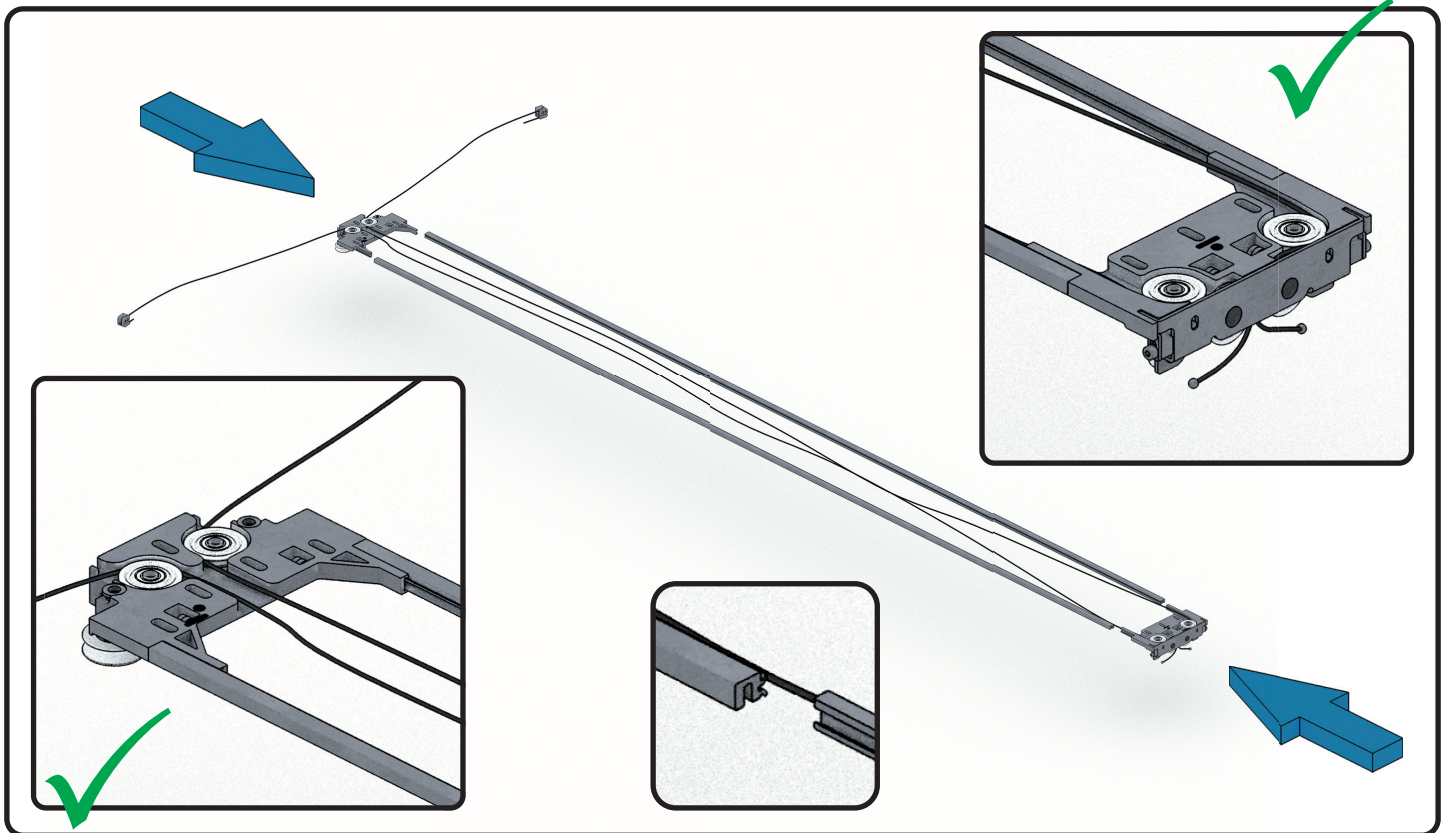

### 3.4

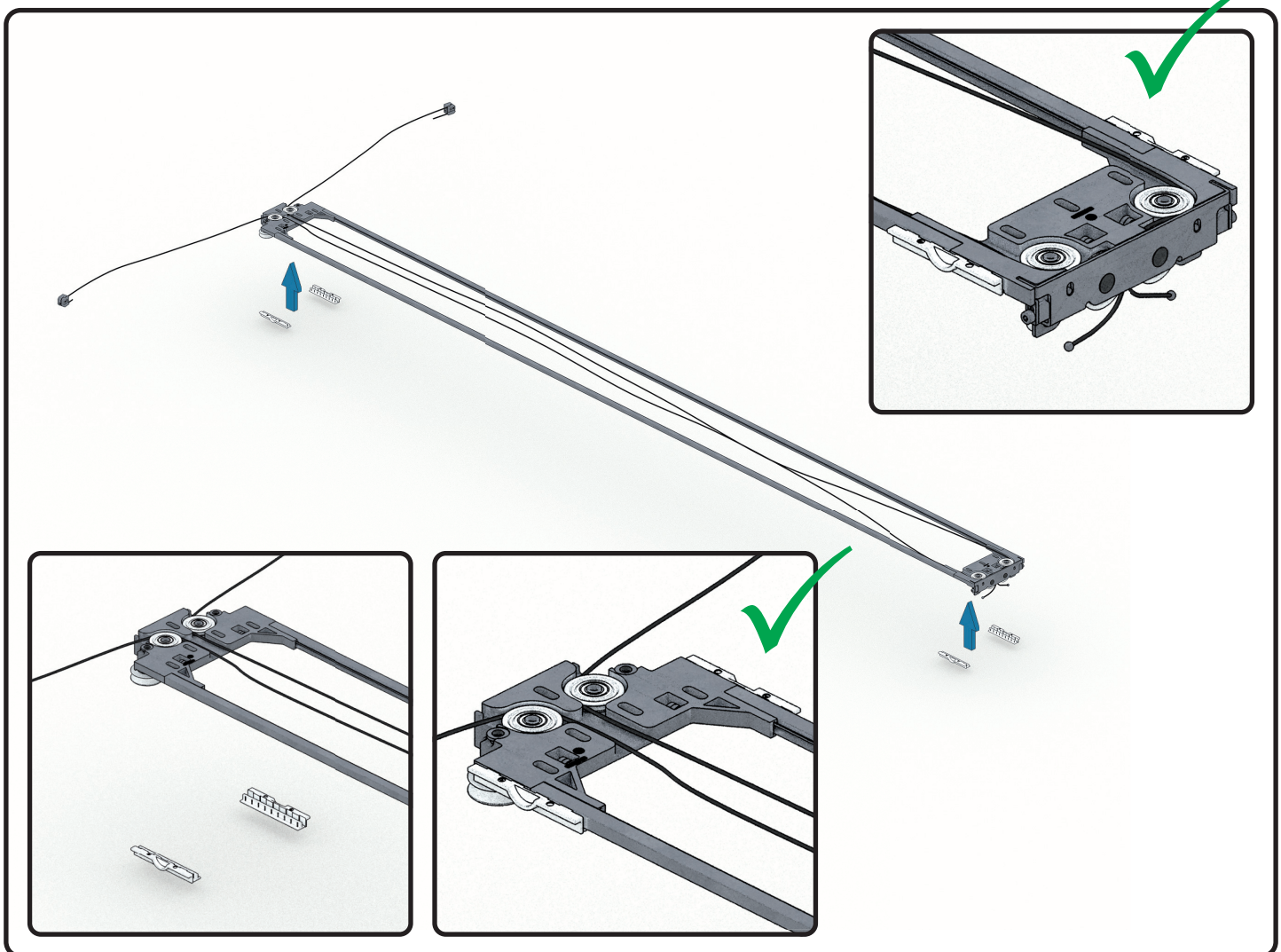



3.5

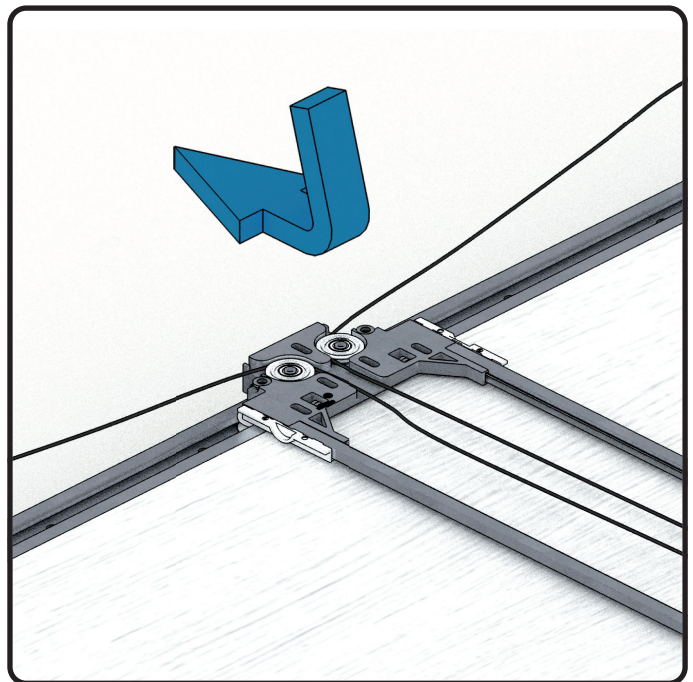
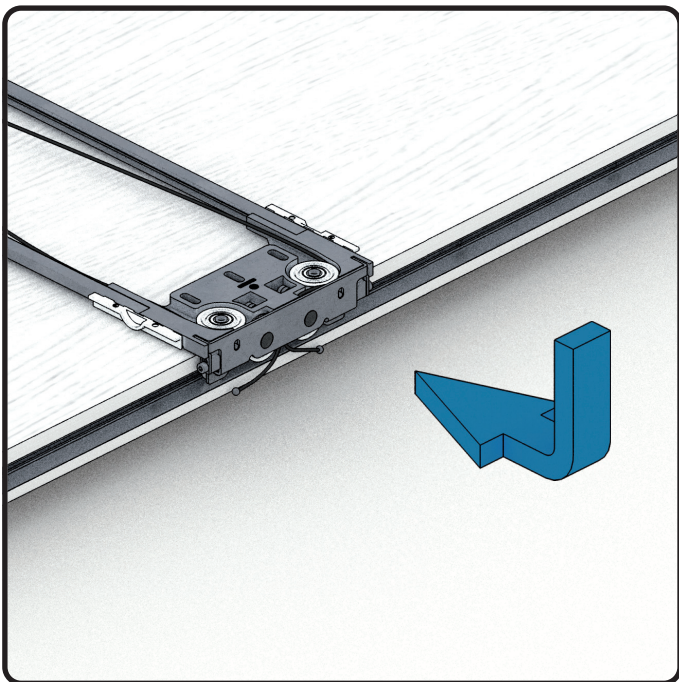
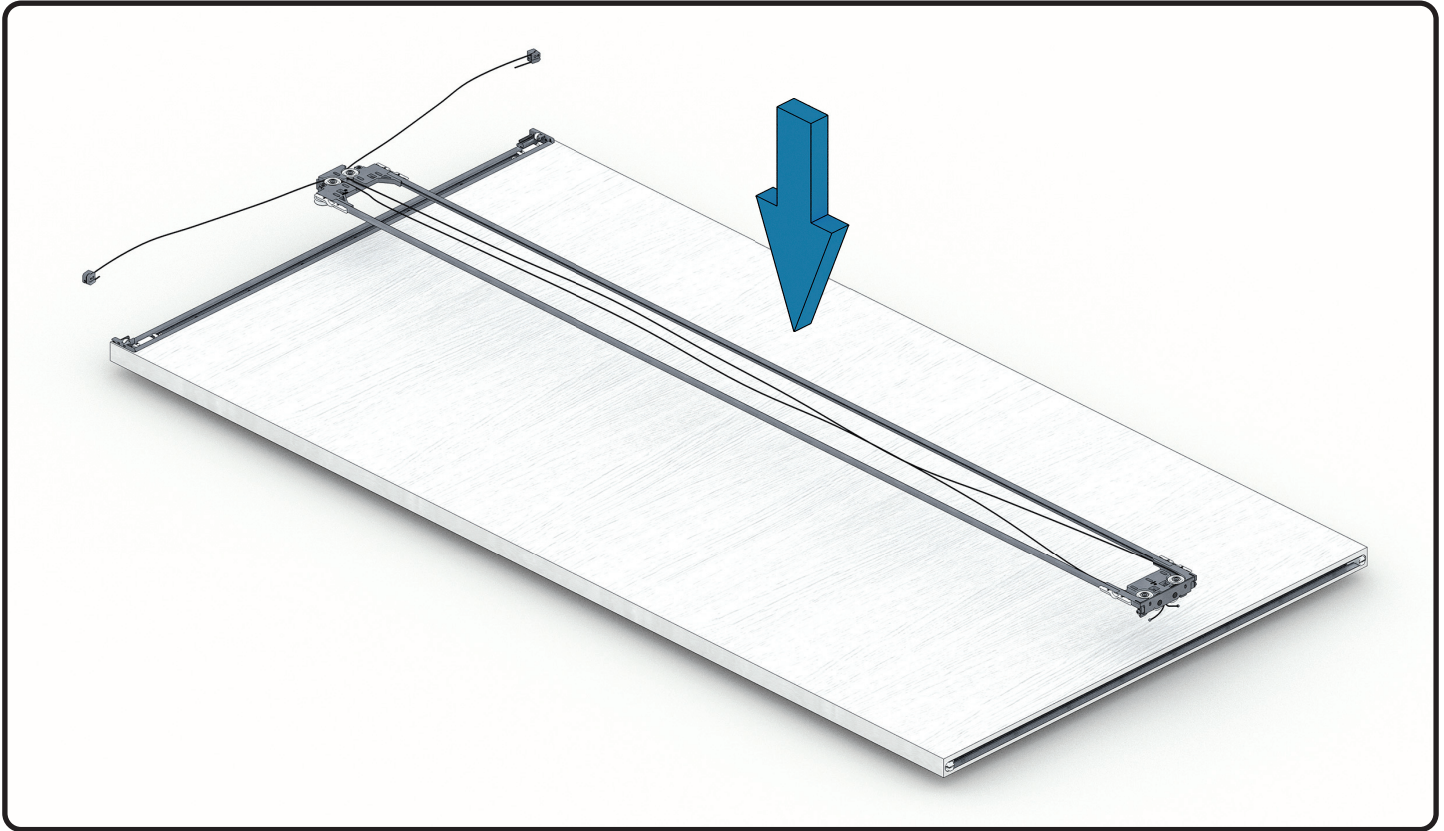



### 3.6

- ① Estendere i tiranti
- ② Extiende los tirantes
- ③ Die Endseilteile ausziehen
- ④ Extend the tie-rods
- ⑤ Etendre les cables
- ⑥ Выпрямить тросы

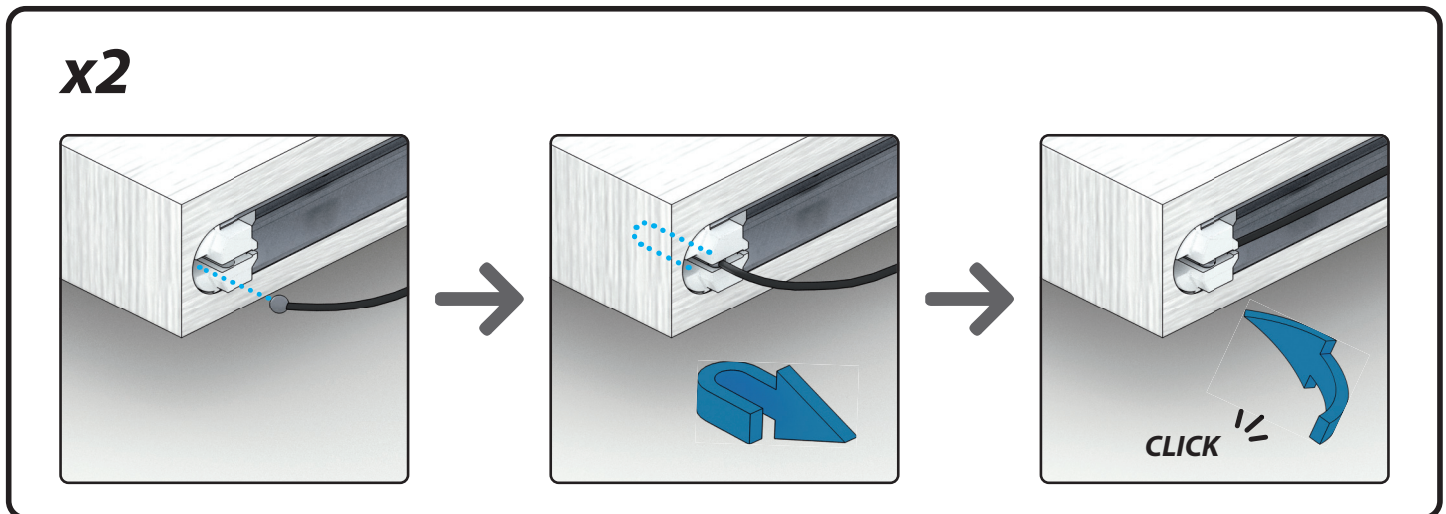
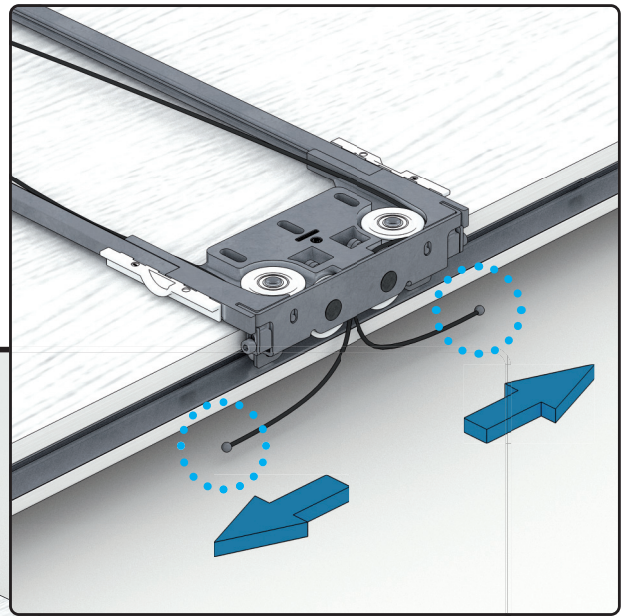
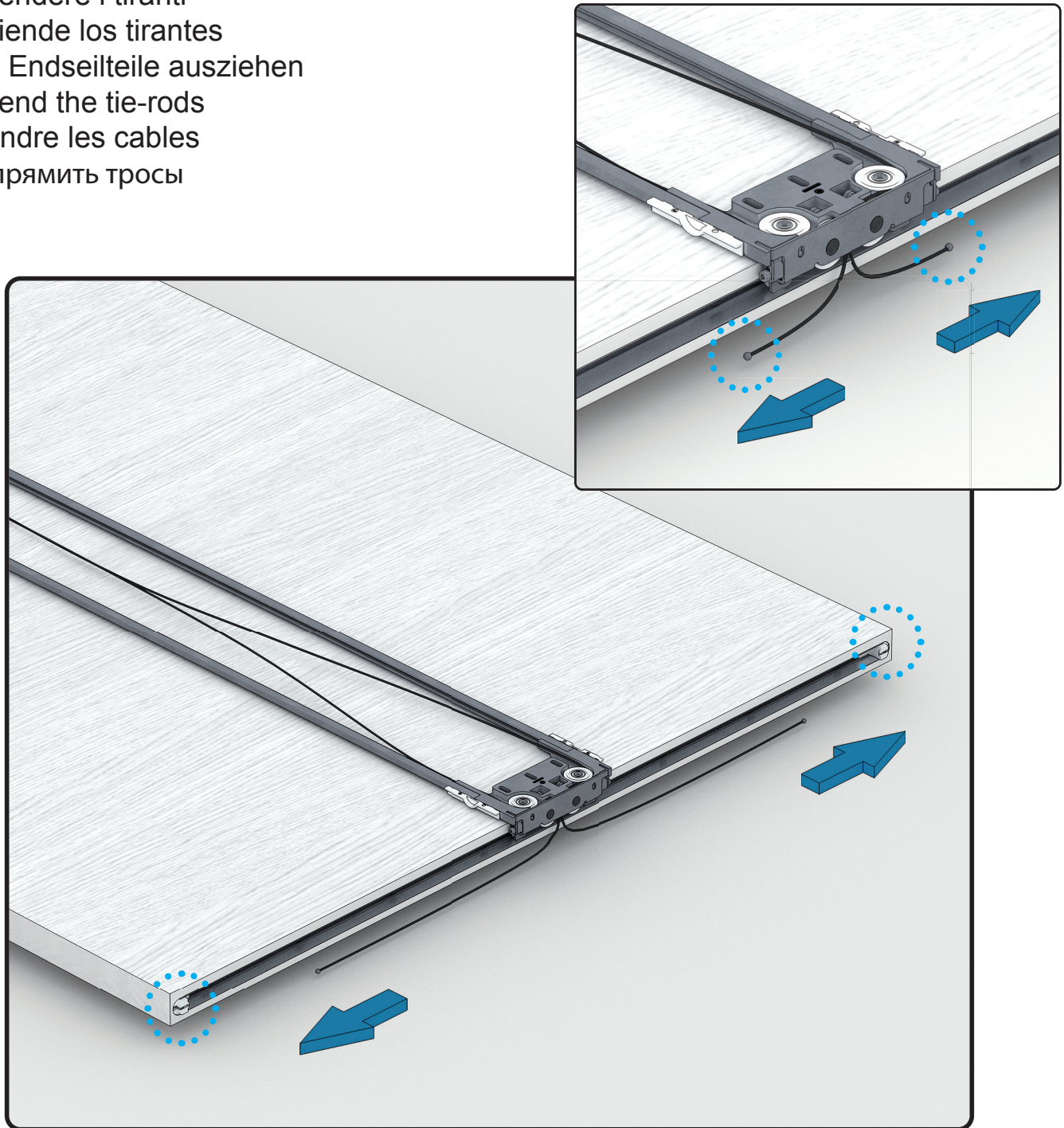

### 3.7

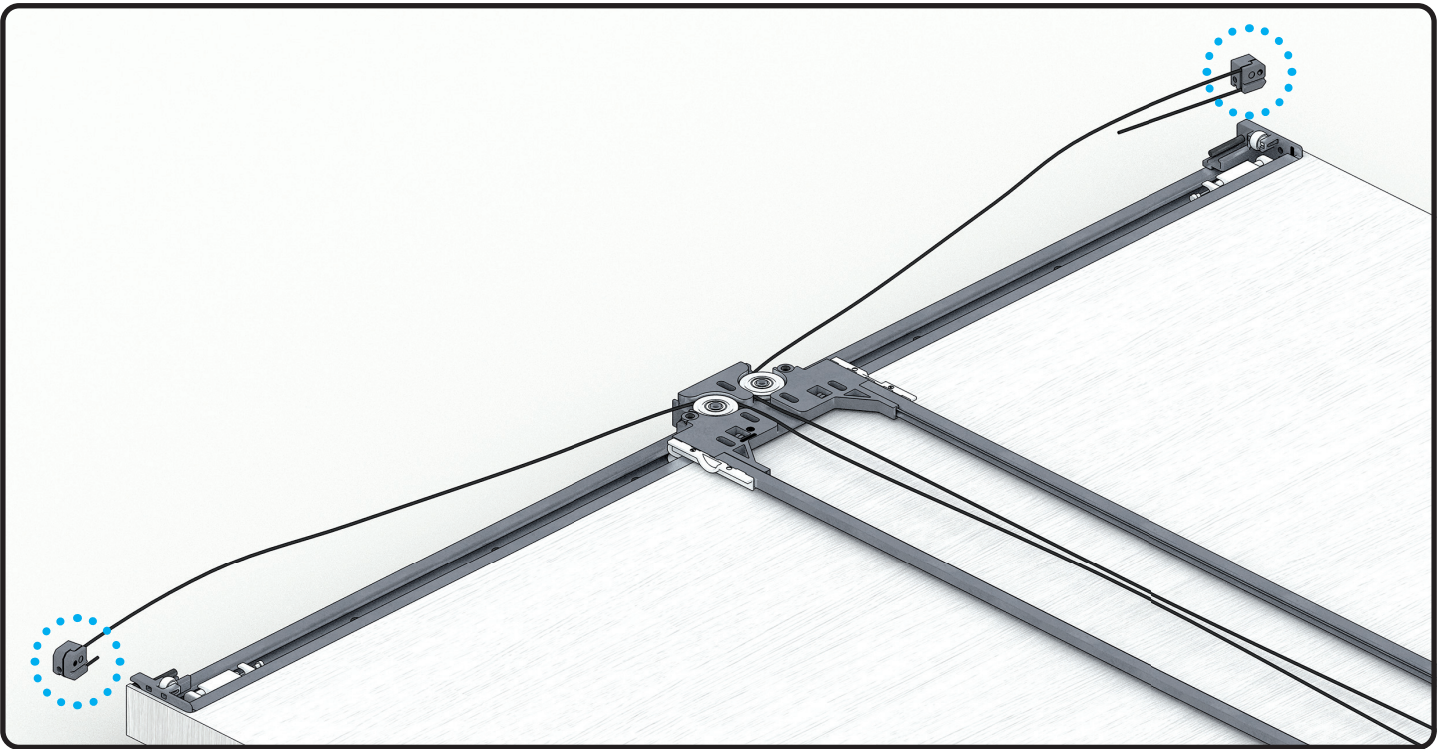



### 3.8

- ⓘ Inserire i tiranti superiori ⓘ Inserte los tirantes superiores
- ⓓ Die oberen Endseilteile einfügen ⓘ Insert the upper tie-rods
- ⓕ Insérer le cable supérieur ⓘ Зафиксировать верхнее крепление троса

**x2**

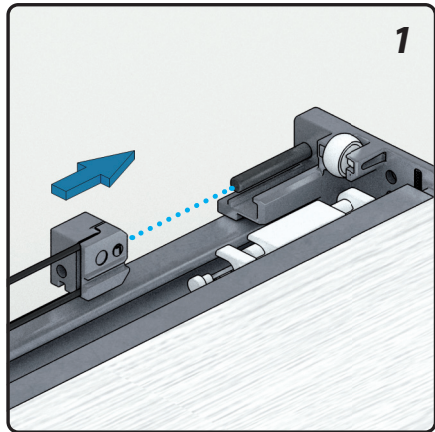

**1**

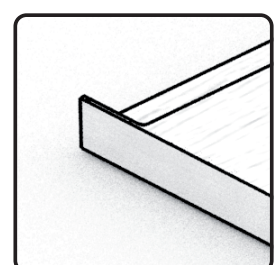

**2**

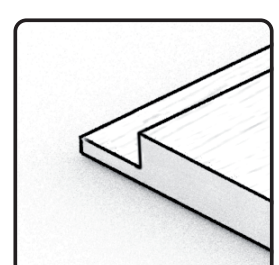

**2**

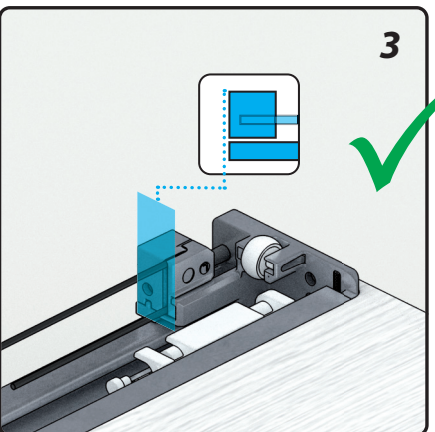

**3**



ⓘ Prima di tensionare i cavi, allineare il telaio come in figura.

ⓔ Antes de tensar los cables, alinee el marco como se muestra.

ⓓ Bevor man die Kabel anzieht, muss der Rahmen wie laut Abbildung aufgelegt werden.

ⓘ Before tightening the cables, adjust the frame like on the image.

ⓕ Avant de mettre en tension les câbles, aligner le panneau comme sur la figure.

ⓕ Прежде чем натянуть тросы, отрегулируйте крепёжную раму, как показано на рисунке.

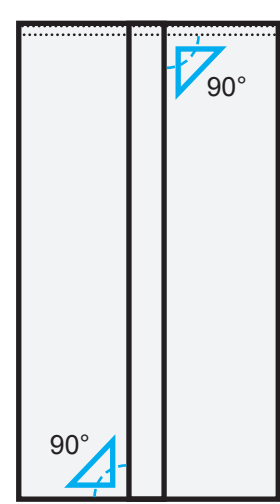

90°

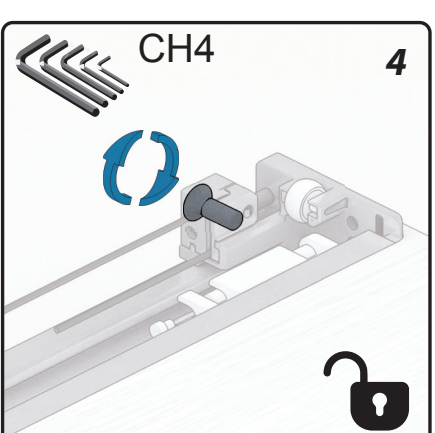

**CH4**

**4**

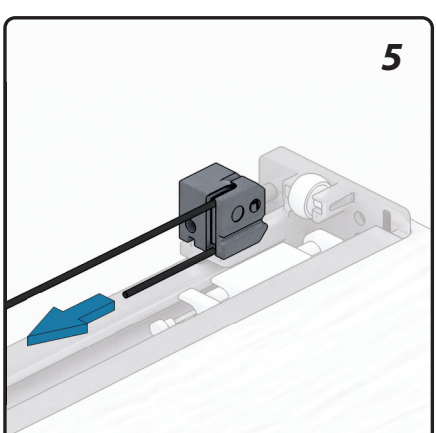

**5**

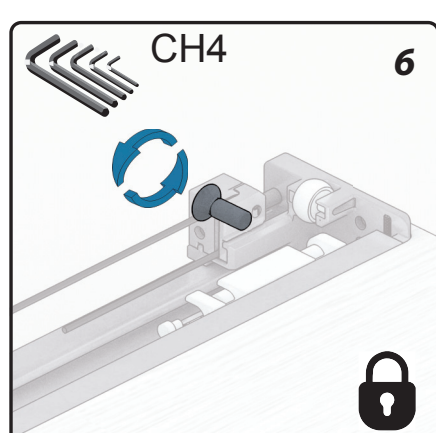

**CH4**

**6**

23

TKKZMIDM09300.indd 23

04/02/20 14:03



3.10

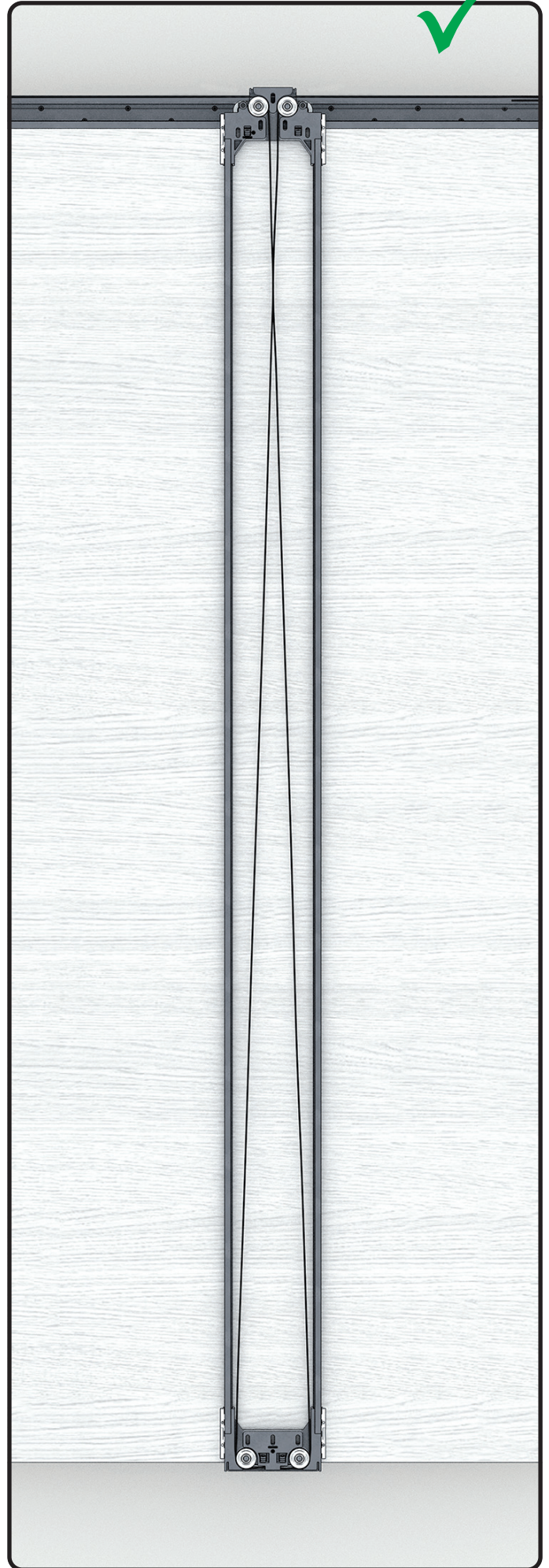
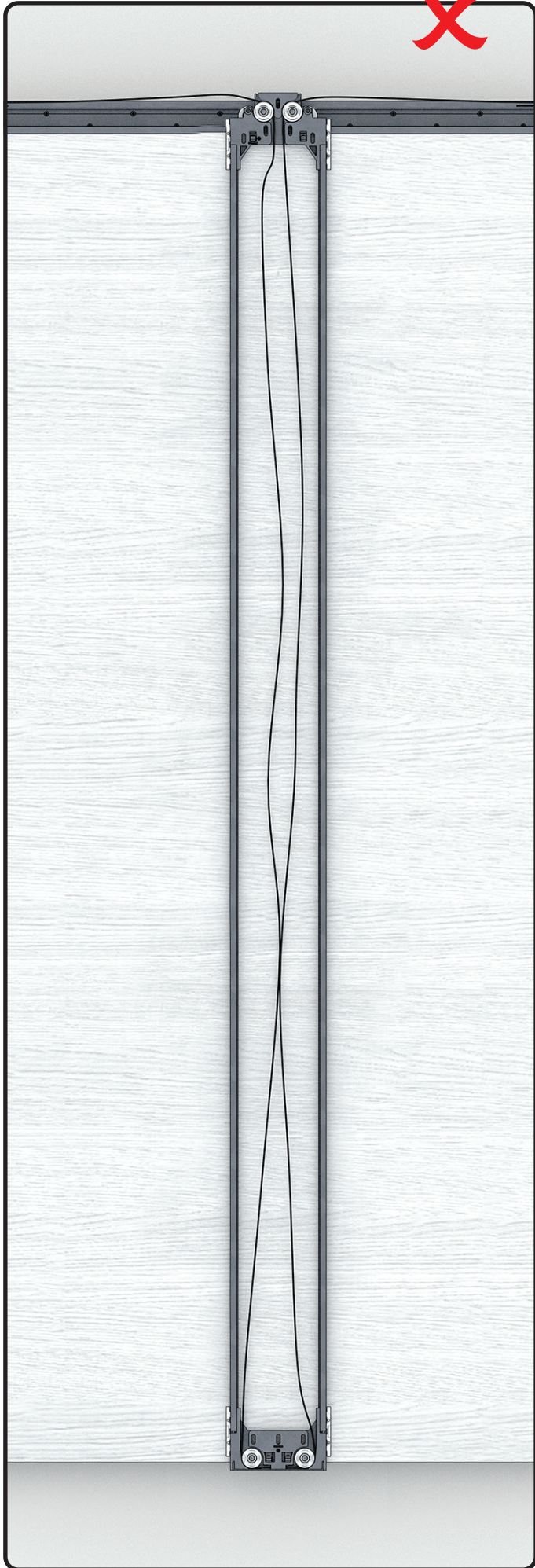

### 3.11

- ⓘ Verifica allineamento telaio    Ⓔ Verifique la alineación del marco  
Ⓓ Prüfen Sie die Position des Rahmen    ⒼⒸ Check the frame adjustment  
Ⓕ Vérifier l'alignement sur le panneau    ⒺⒼⒸ Проверьте на сколько ровно установлена крепёжная рама

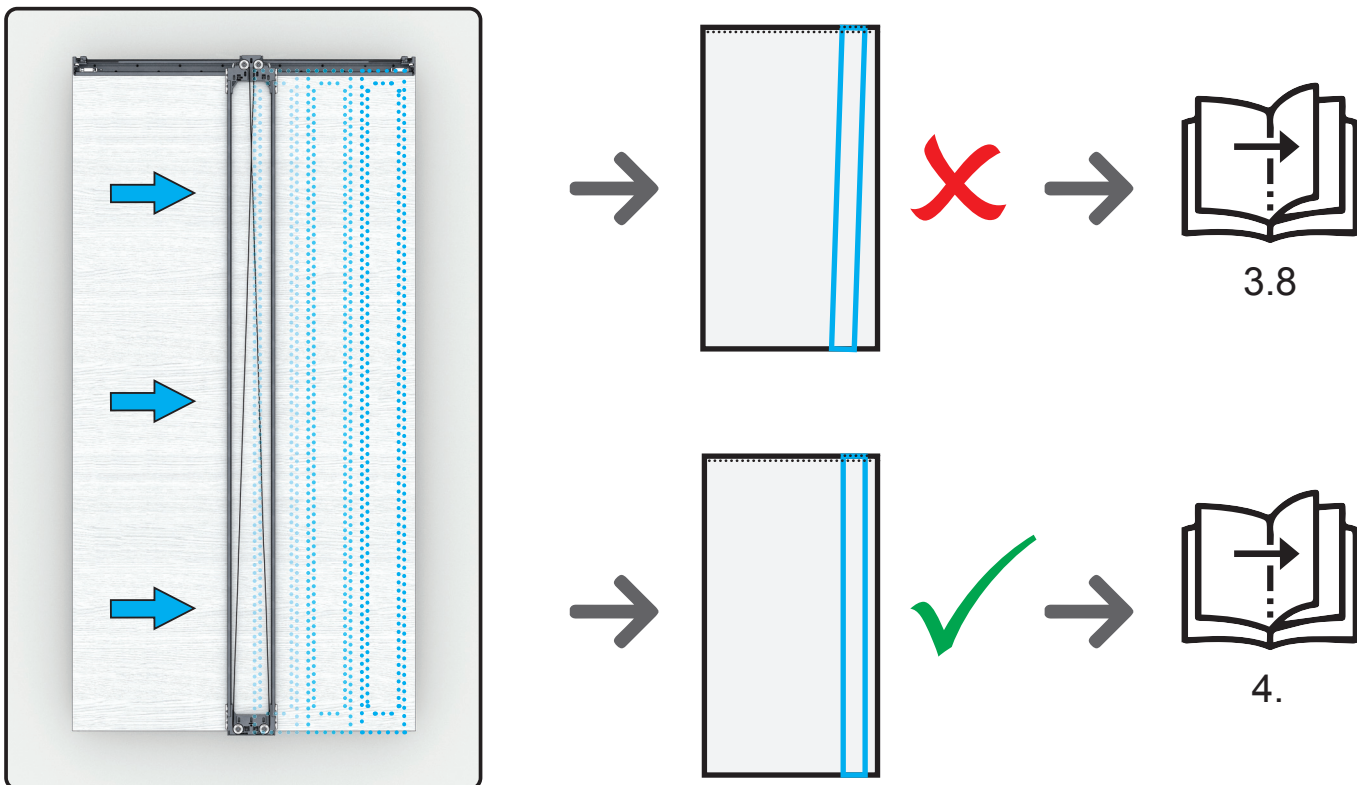



- ① 4. Installazione
- ② 4. Instalación
- ③ 4. Einbau
- ④ 4. Installation
- ⑤ 4. Installation
- ⑥ 4. Установка

① Mobili ② Muebles ③ Möbel  
④ Furniture ⑤ Muebles ⑥ Мебели

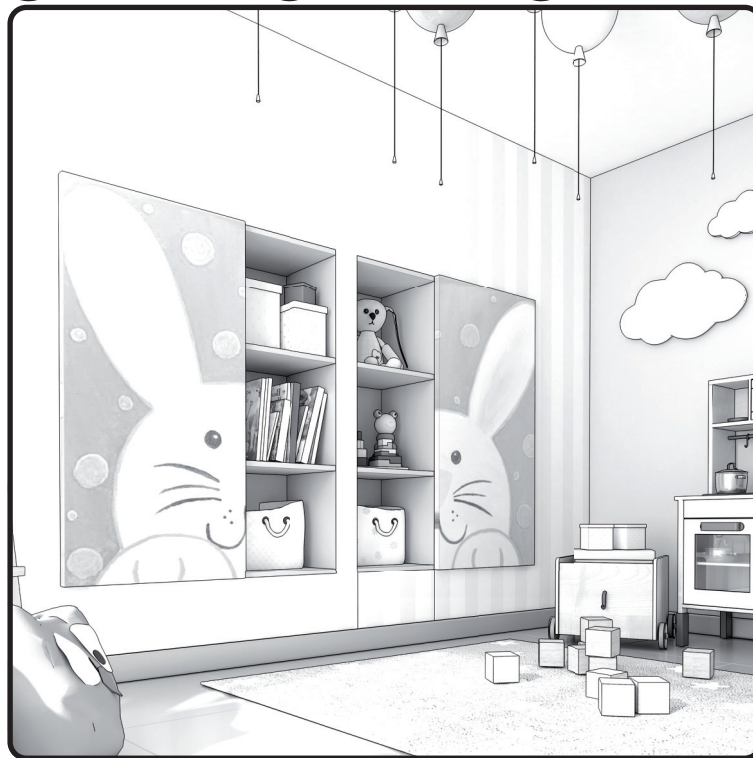

① Porte ② Puertas ③ Türen  
④ Doors ⑤ Portes ⑥ Дверей



## 4.1

- ⓐ Scollegare i cavi come da sequenza indicata
- ⓑ Desconecte los cables como se muestra en la secuencia
- ⓒ Die Kabel laut Abbildung lösen
- ⓓ Disconnect the cables as indicated in the sequence
- ⓔ Mettre les câbles comme indiqué sur la séquence
- ⓕ Натяните тросы в указанной последовательности

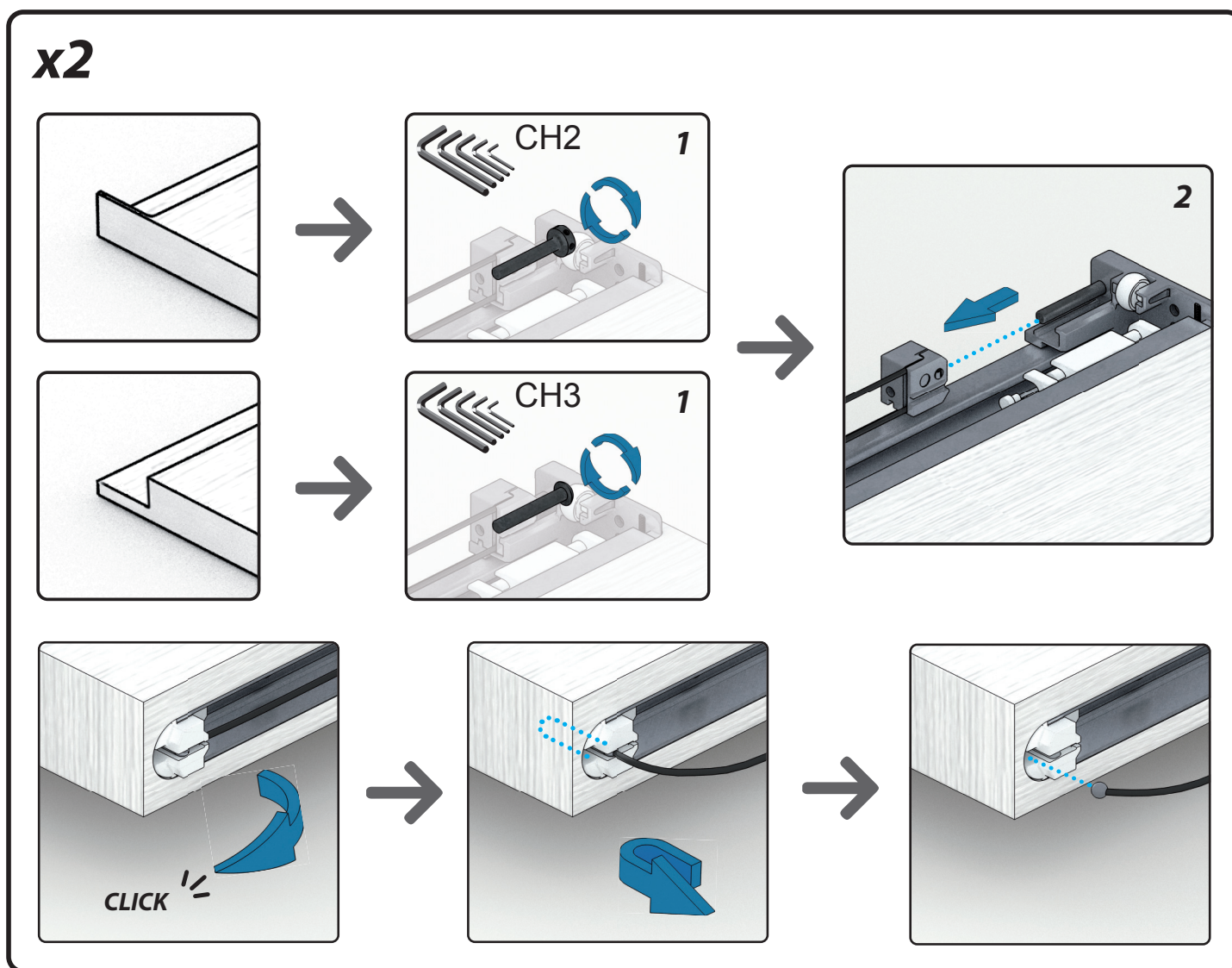



## 4.2

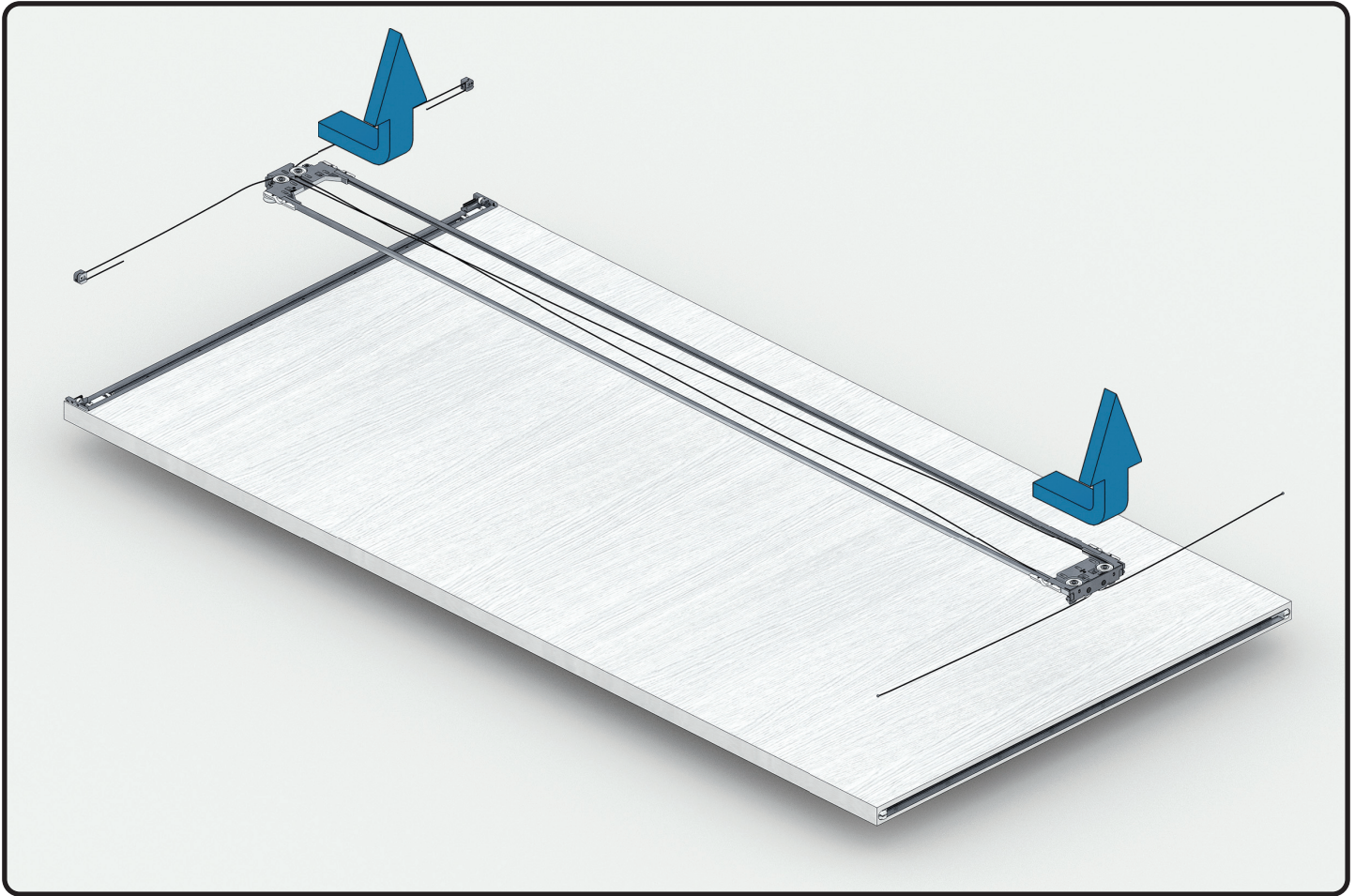

## 4.3

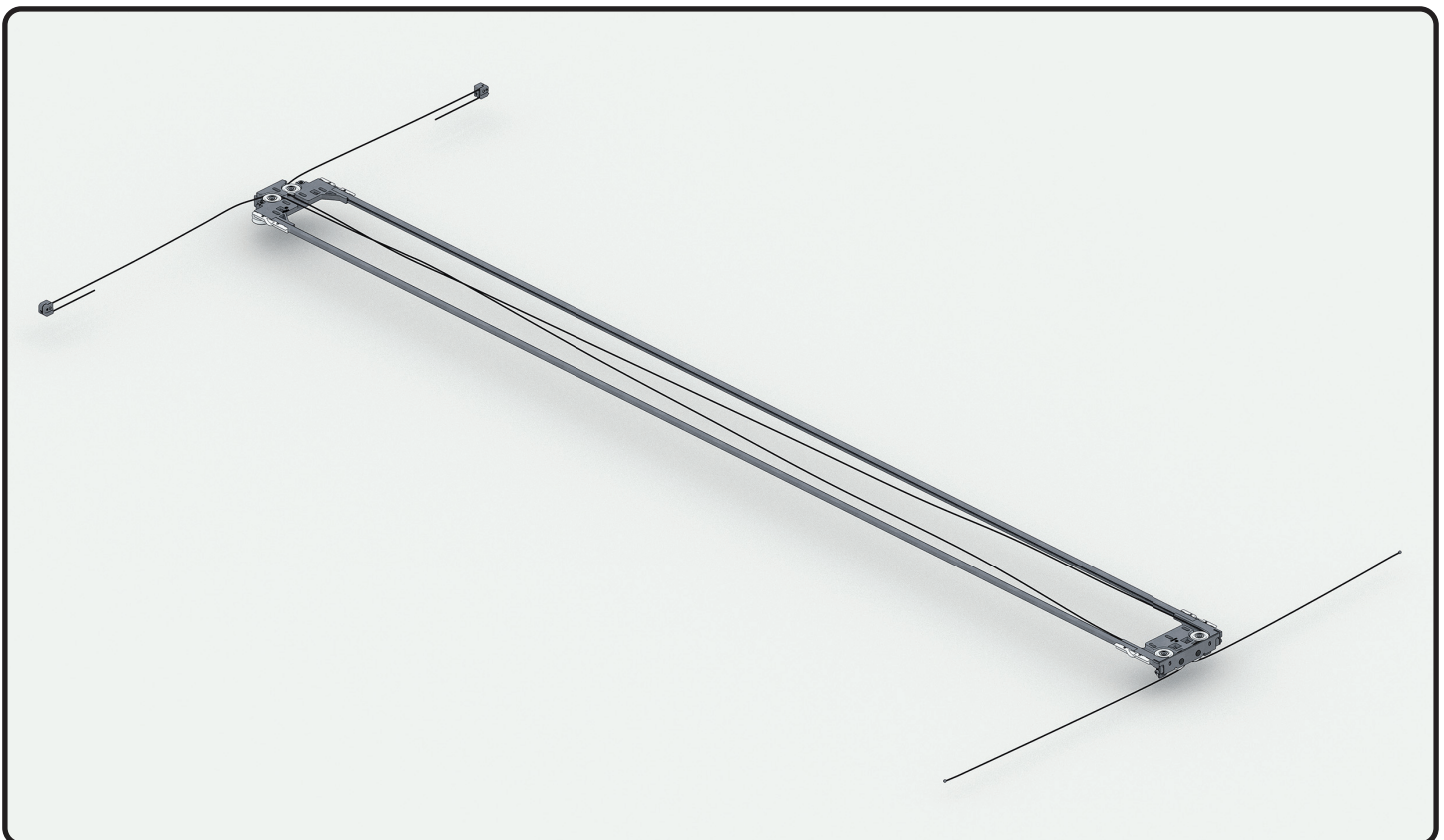

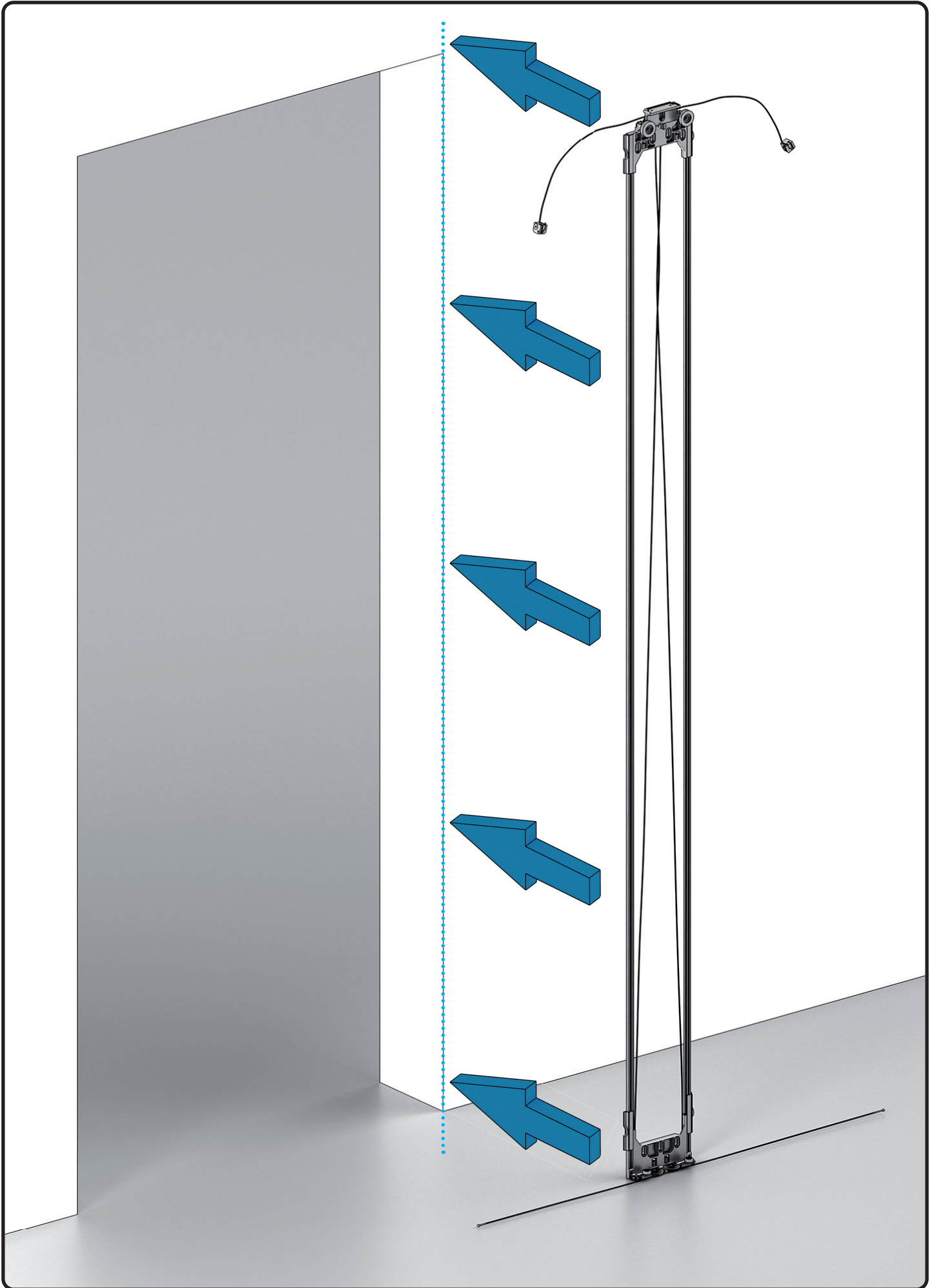



4.5

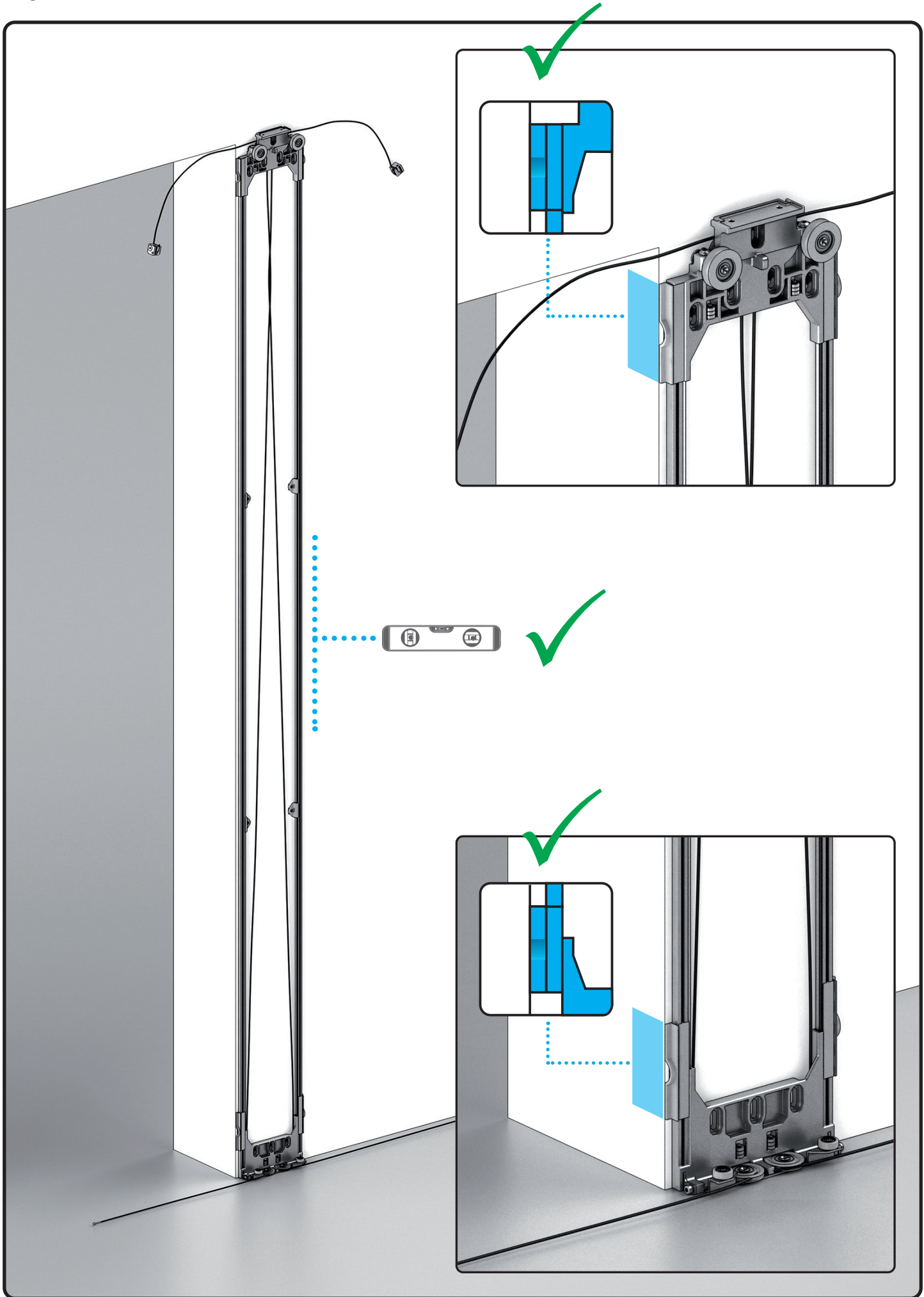

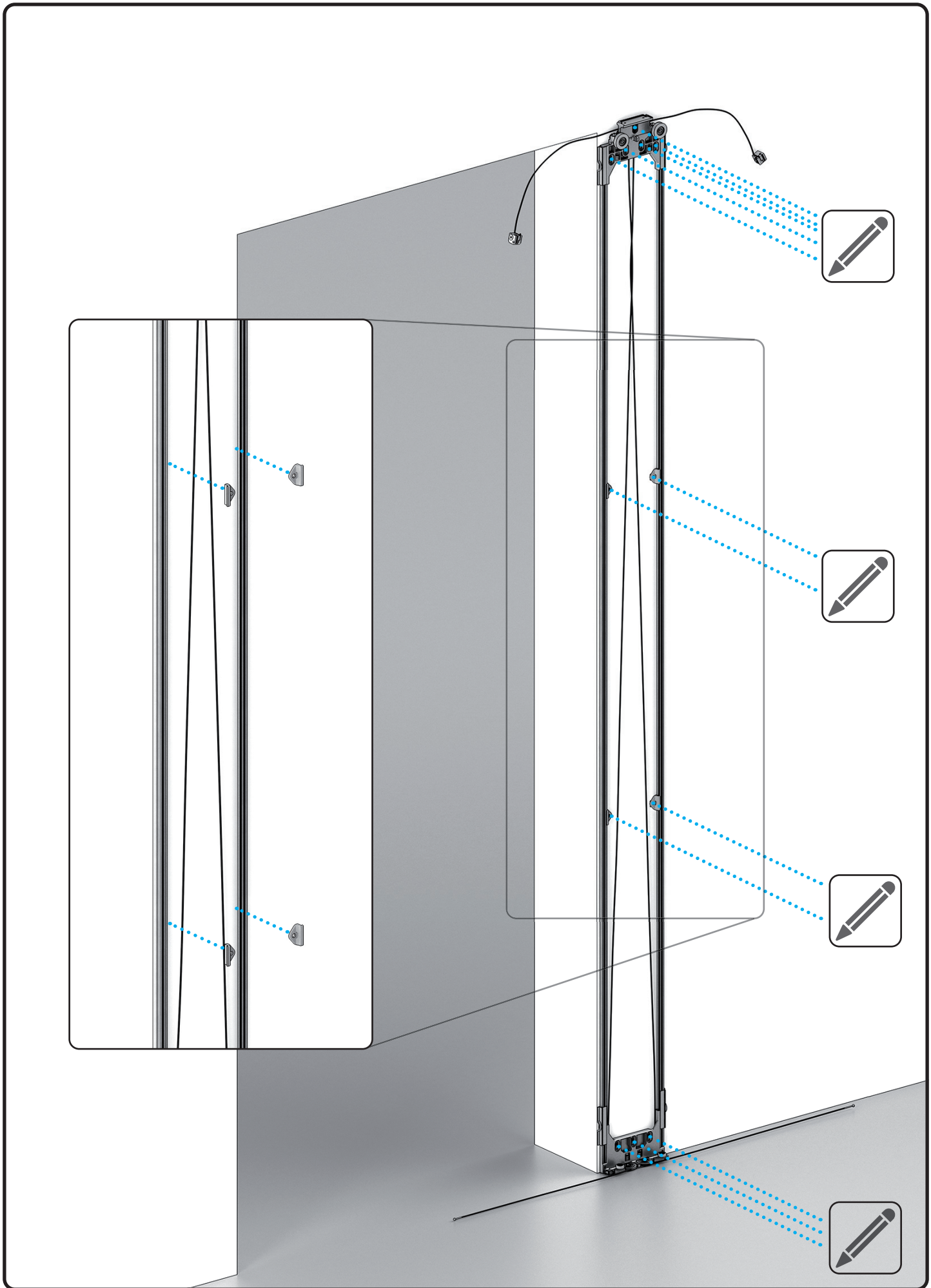



# 4.7

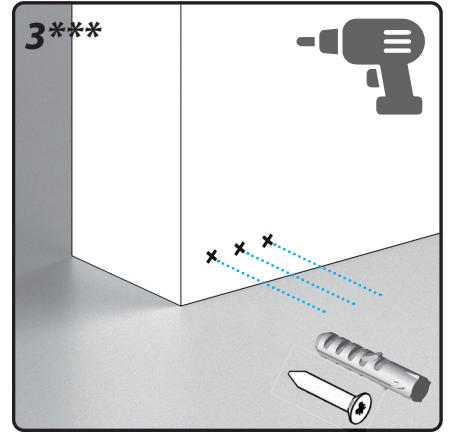
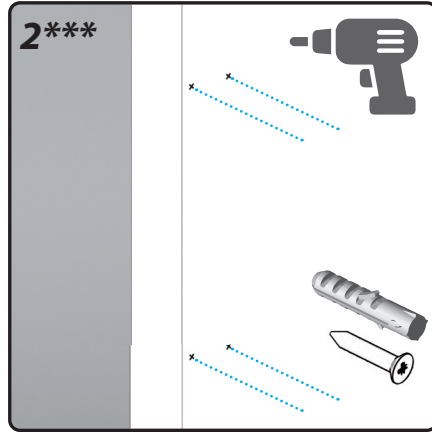
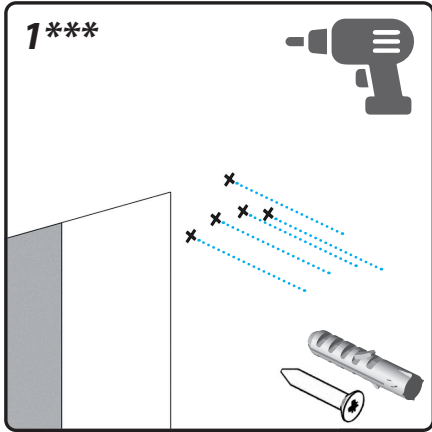

# 4.8

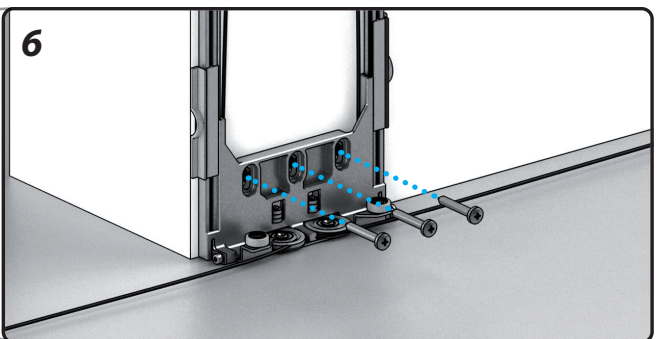
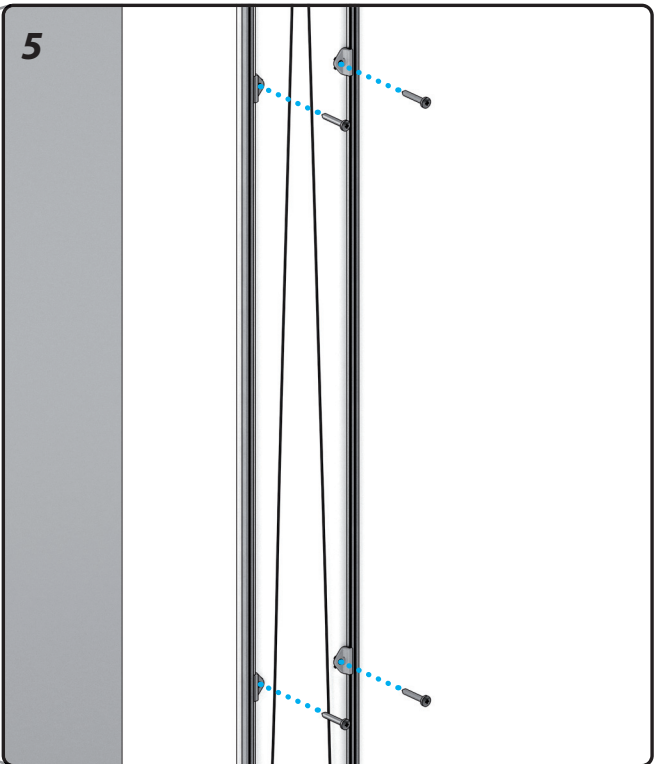
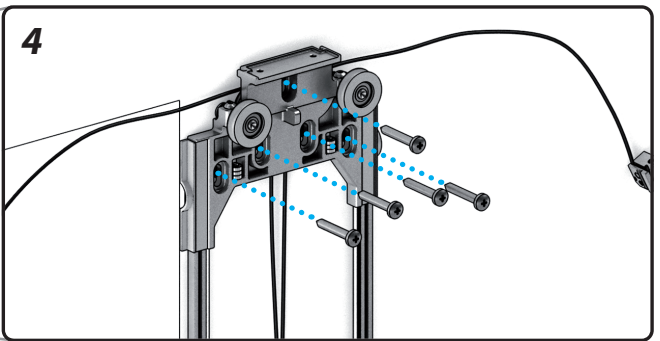
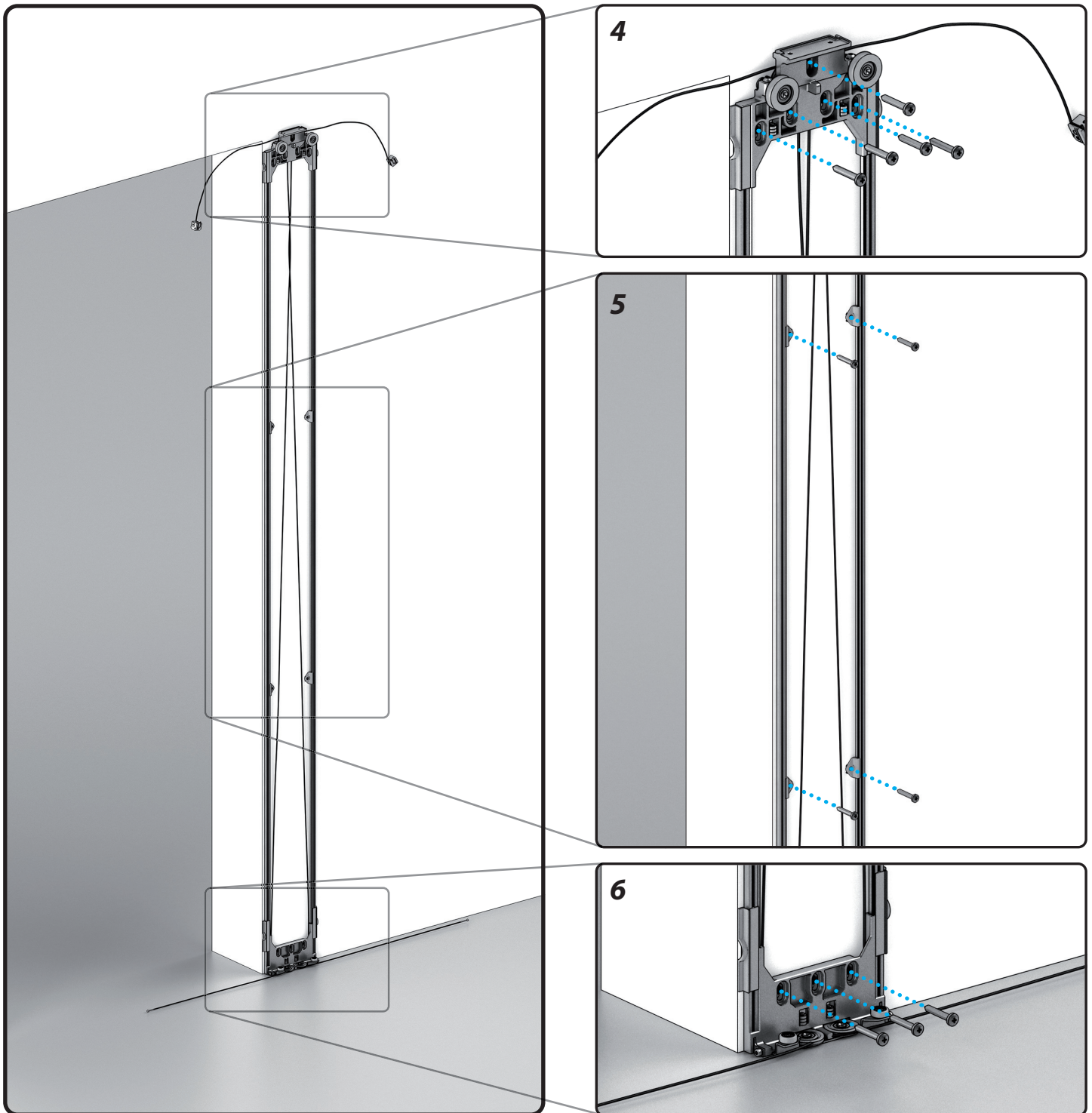

## 4.9

- ① Staccare le placchette
- ② Quitar las placas
- ③ Plättchen entfernen
- ④ Detach the plates
- ⑤ Détacher les plaquettes
- ⑥ Убрать пластины

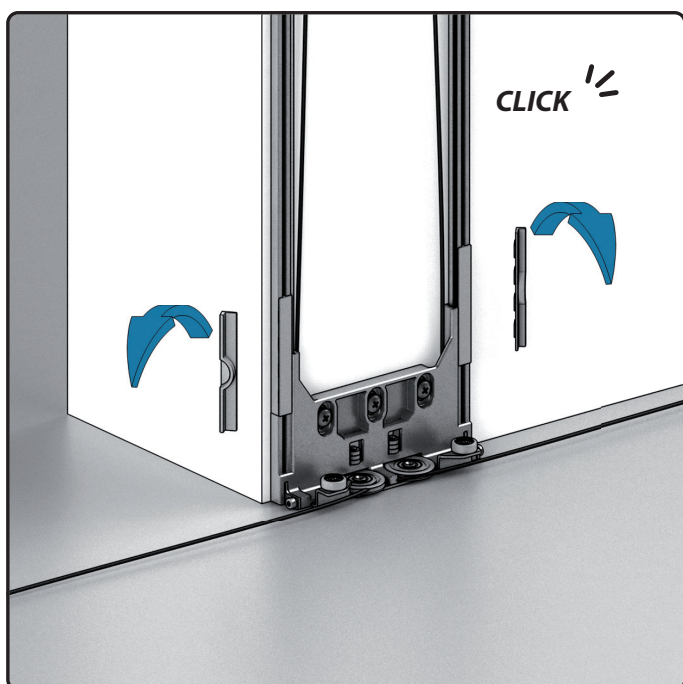
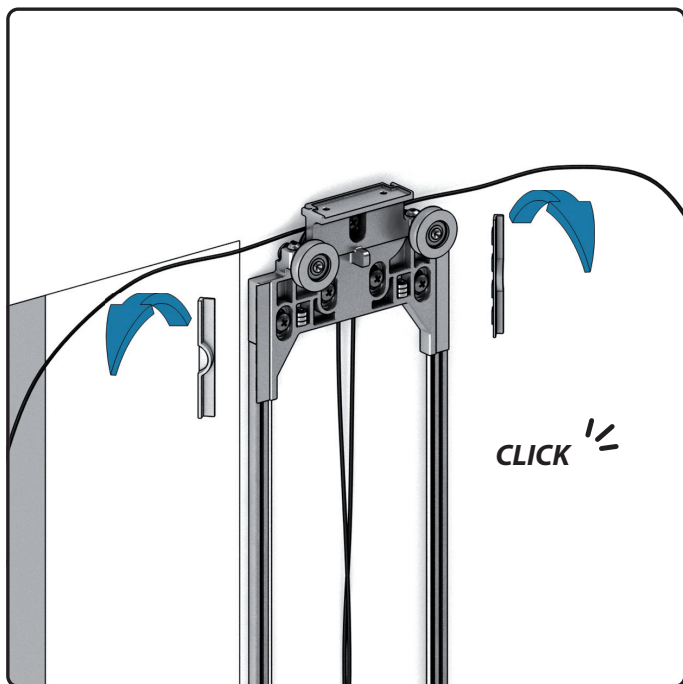

## 4.10





- ① 5. Montaggio pannello
- ② 5. Montaje del panel
- ③ 5. Türblatt Montage
- ④ 5. Door leaf installation
- ⑤ 5. Montage du panneau
- ⑥ 5. Установка дверного полотна

5.1

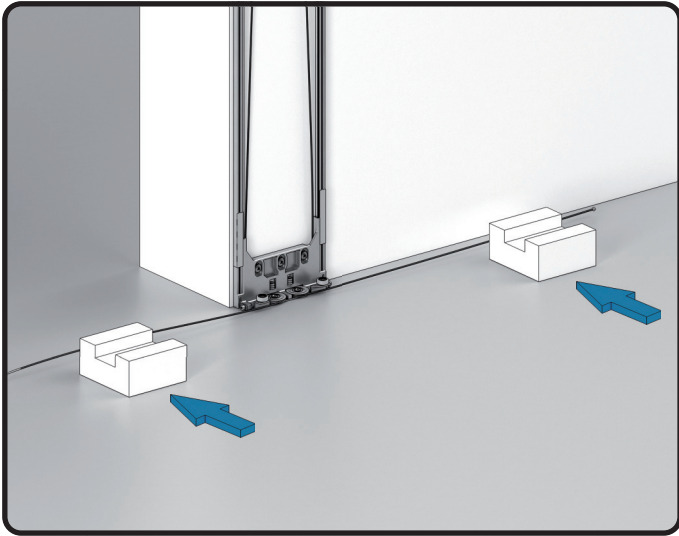

5.2

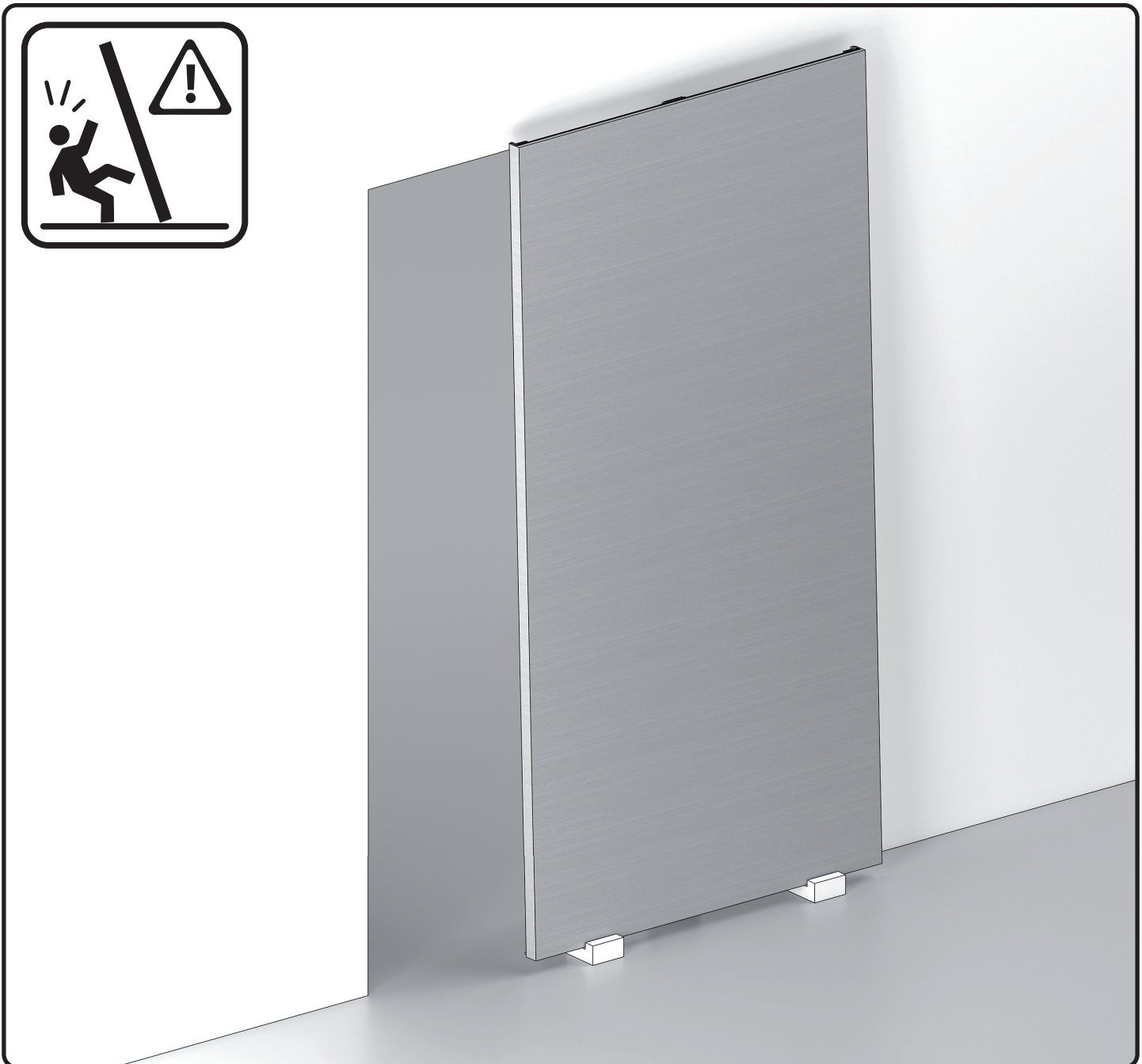



5.3

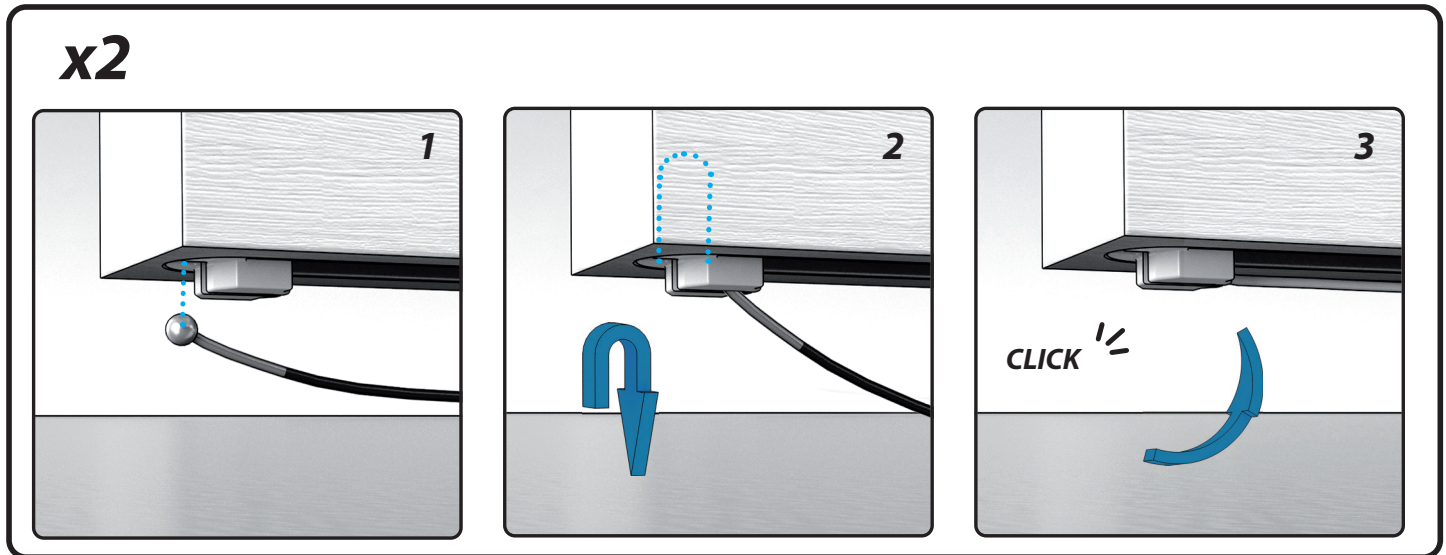

5.4

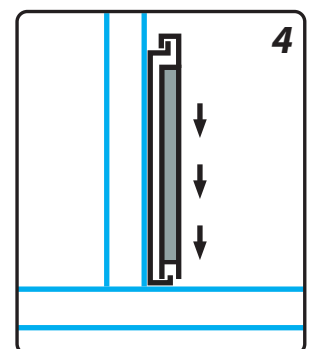
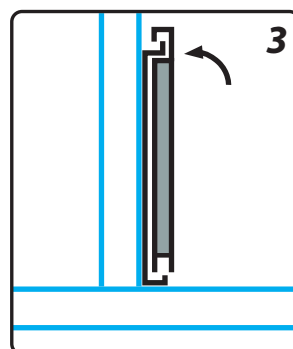
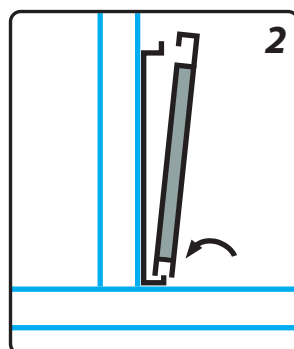
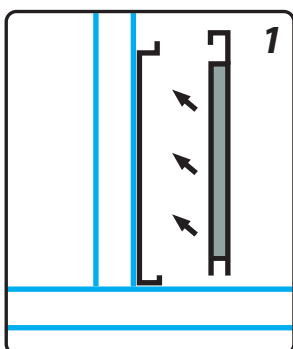
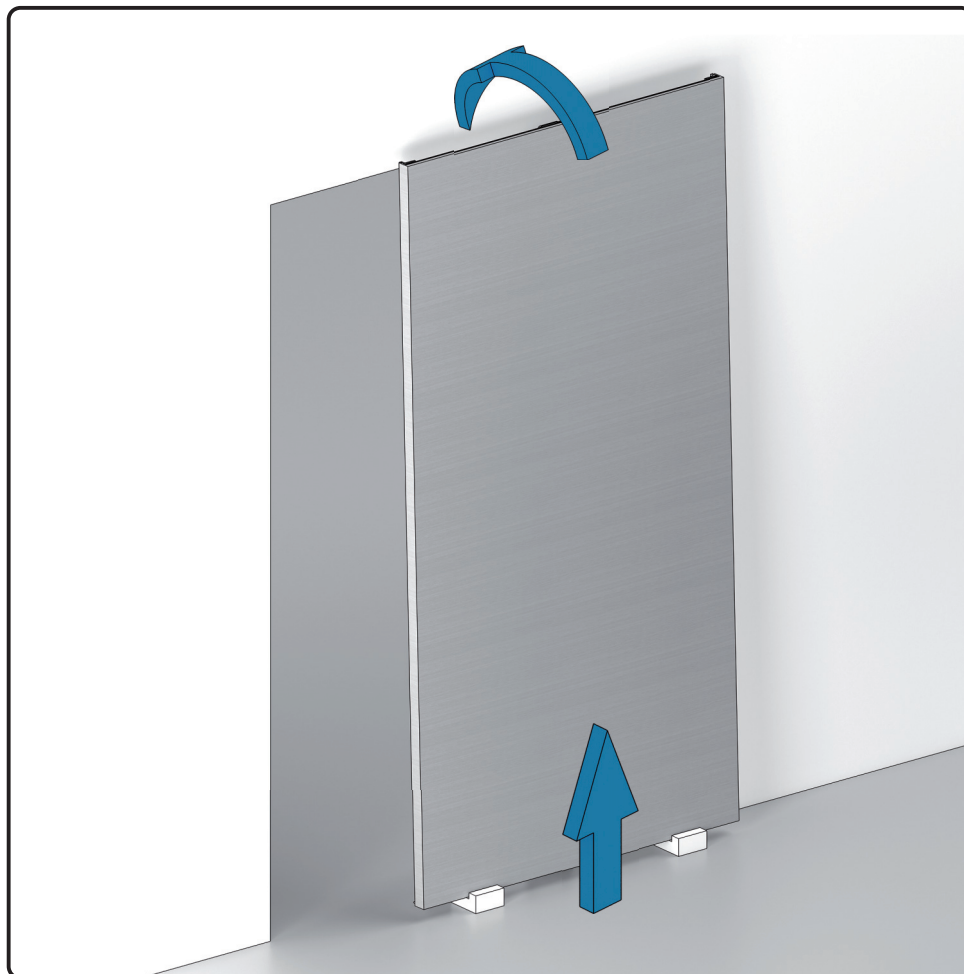

### 5.5

- ⓘ Dettaglio superiore
- Ⓔ Detalle superior
- ⓓ Obere Detailansicht
- Ⓖⓑ Upper installation detail
- Ⓕ F Détail supérieur
- Ⓕⓑ Верхний механизм



### 5.6

- ⓘ Dettaglio inferiore
- Ⓔ Detalle inferior
- ⓓ Untere Detailansicht
- Ⓖⓑ Lower installation detail
- Ⓕ F Détail inférieur
- Ⓕⓑ Нижний механизм



### 5.7

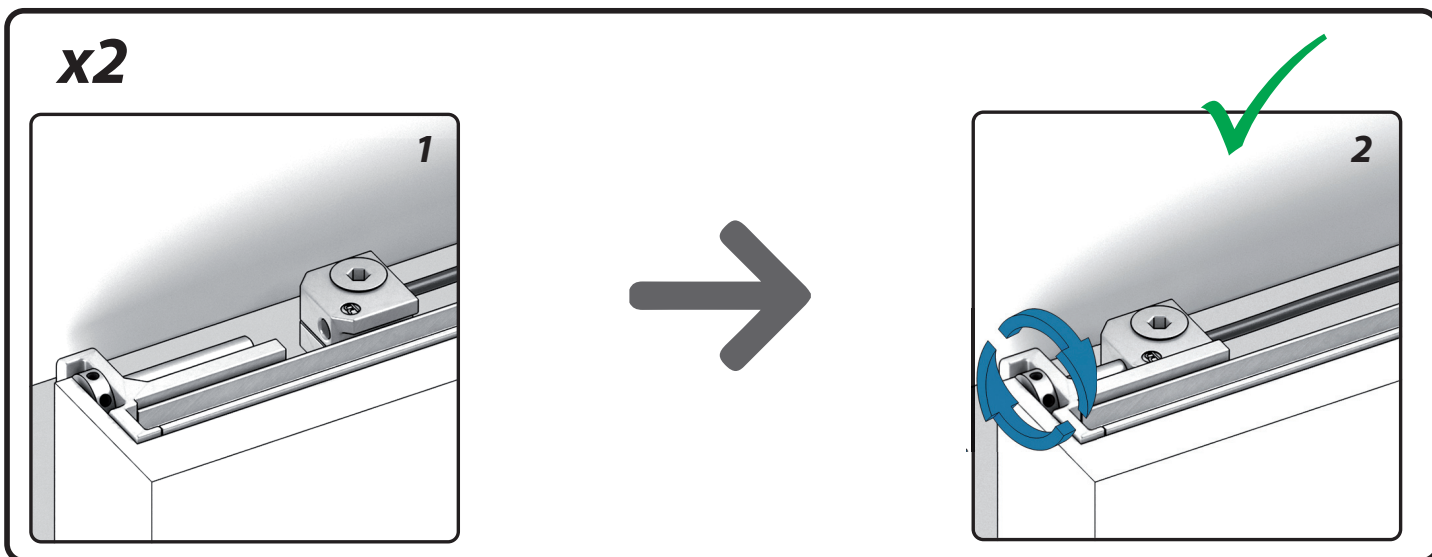



5.8

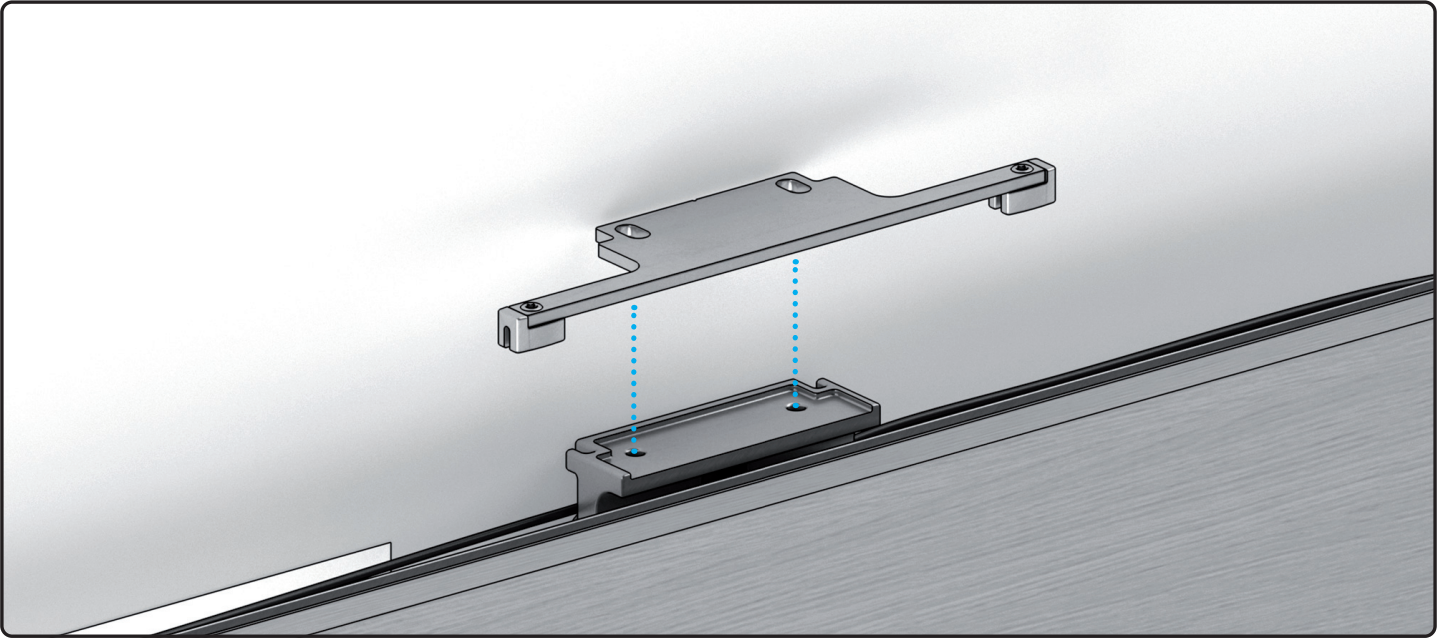

5.8

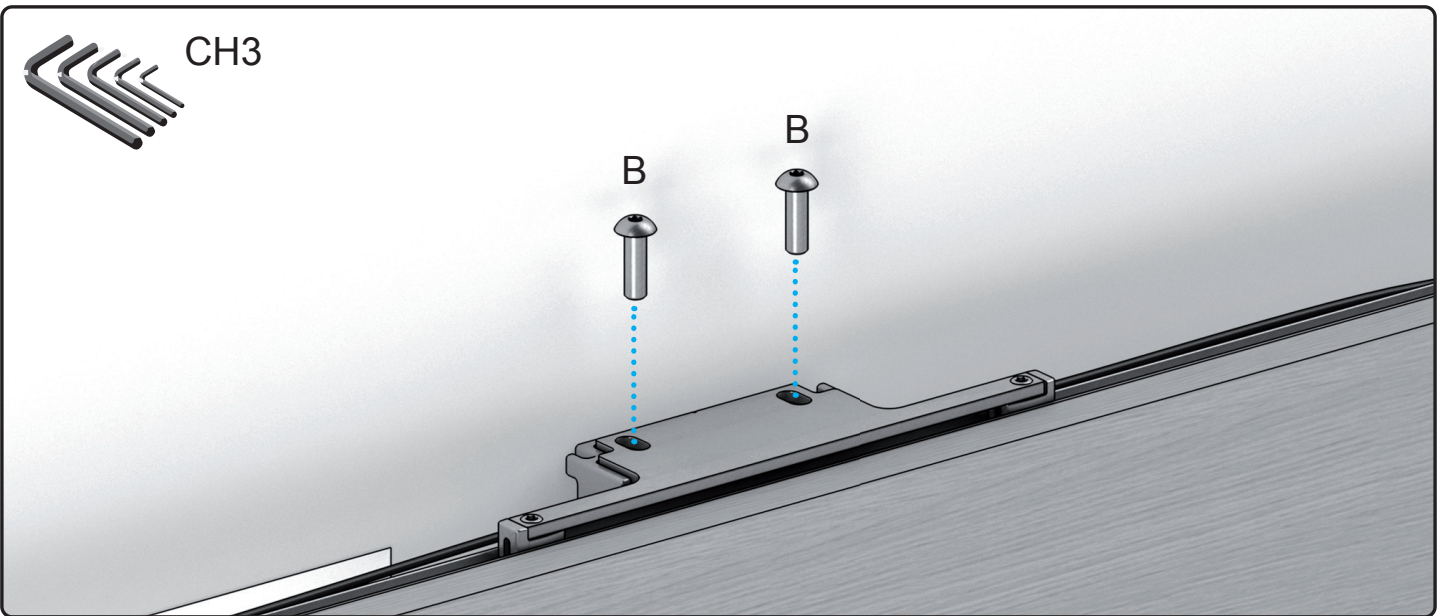



- ① 6. Regolazioni
- ② 6. Ajustes
- ③ 6. Justierung
- ④ 6. Adjustments
- ⑤ 6. Réglages
- ⑥ 6. Регулировка



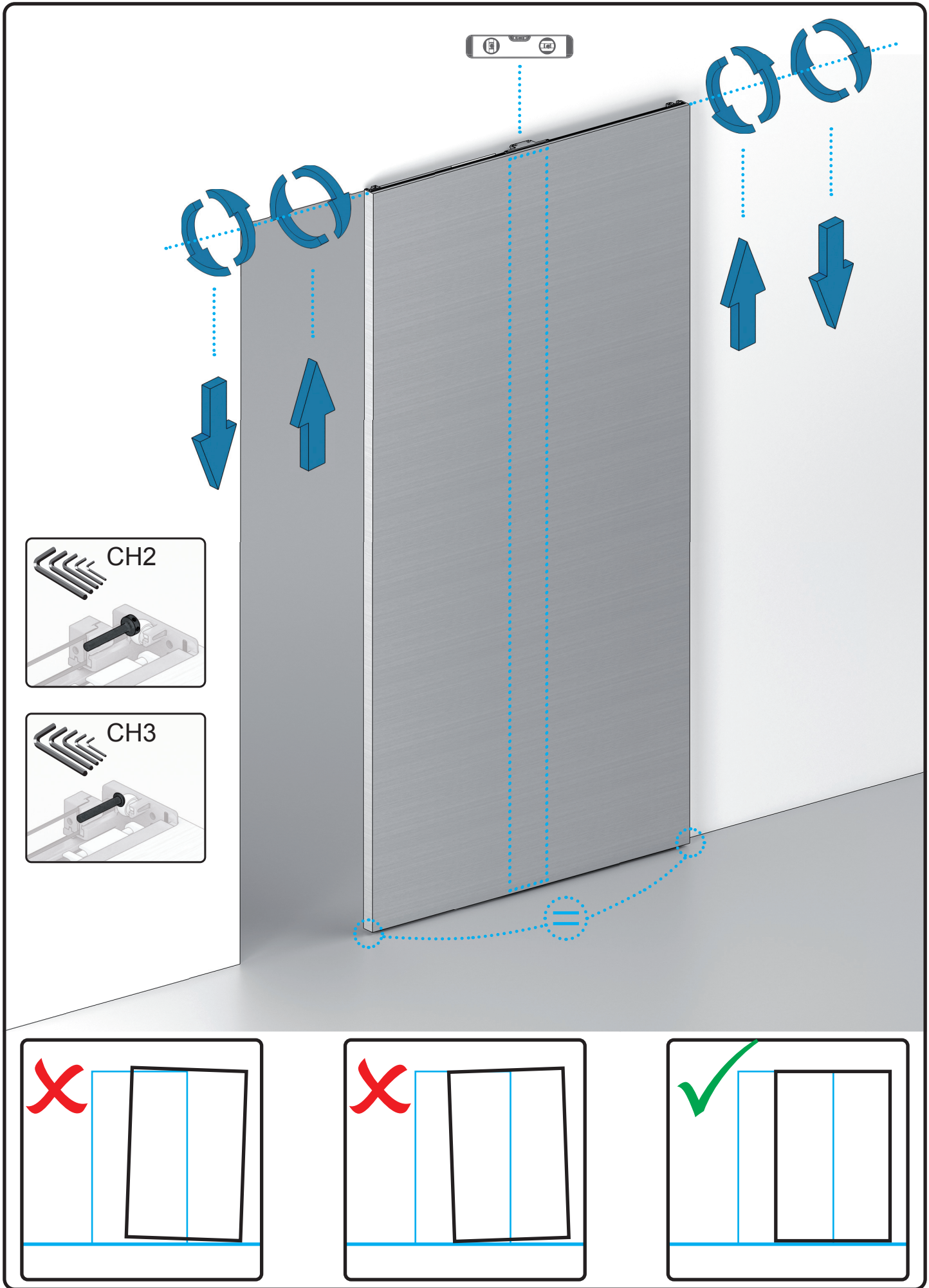

6.2

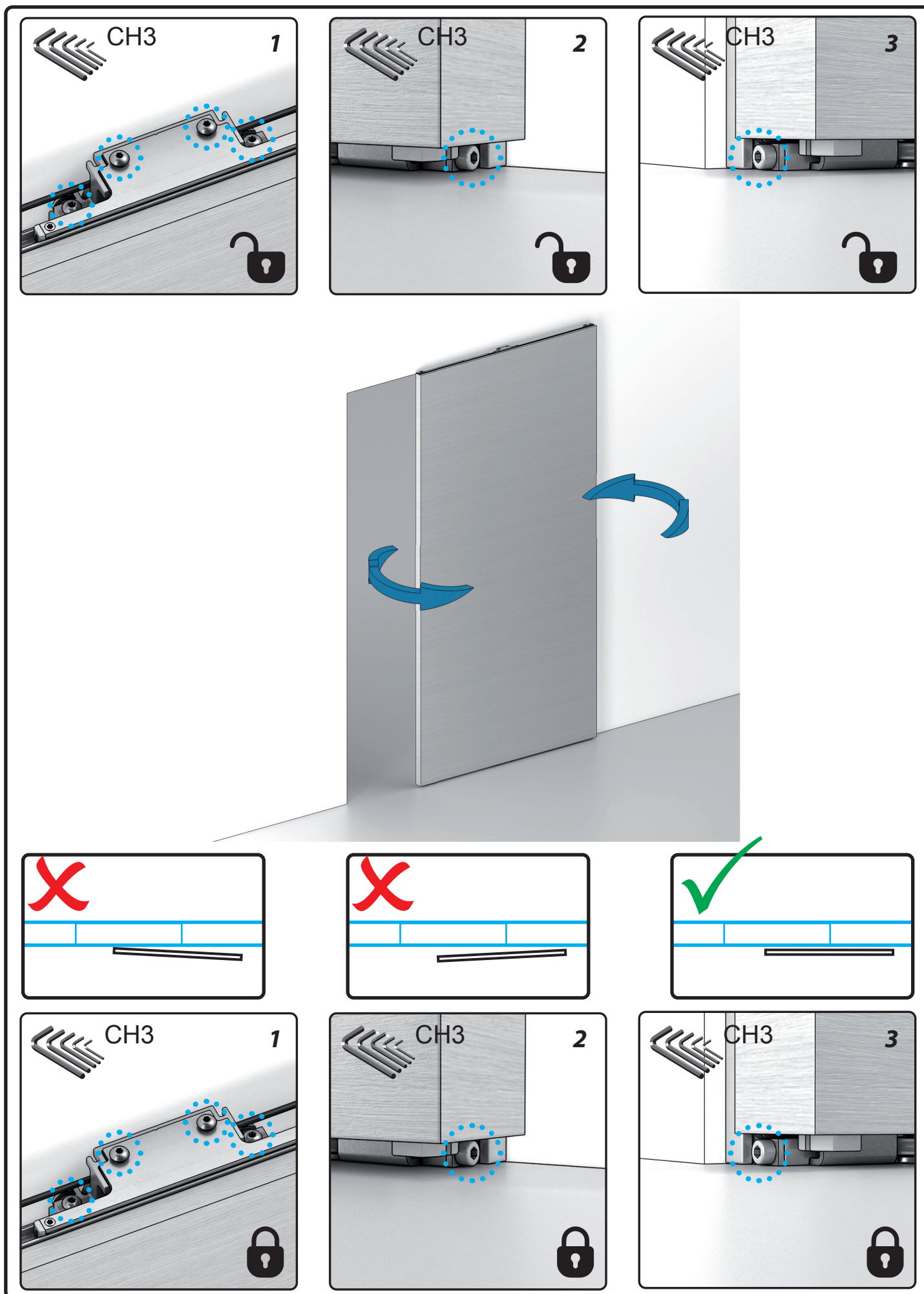



6.3

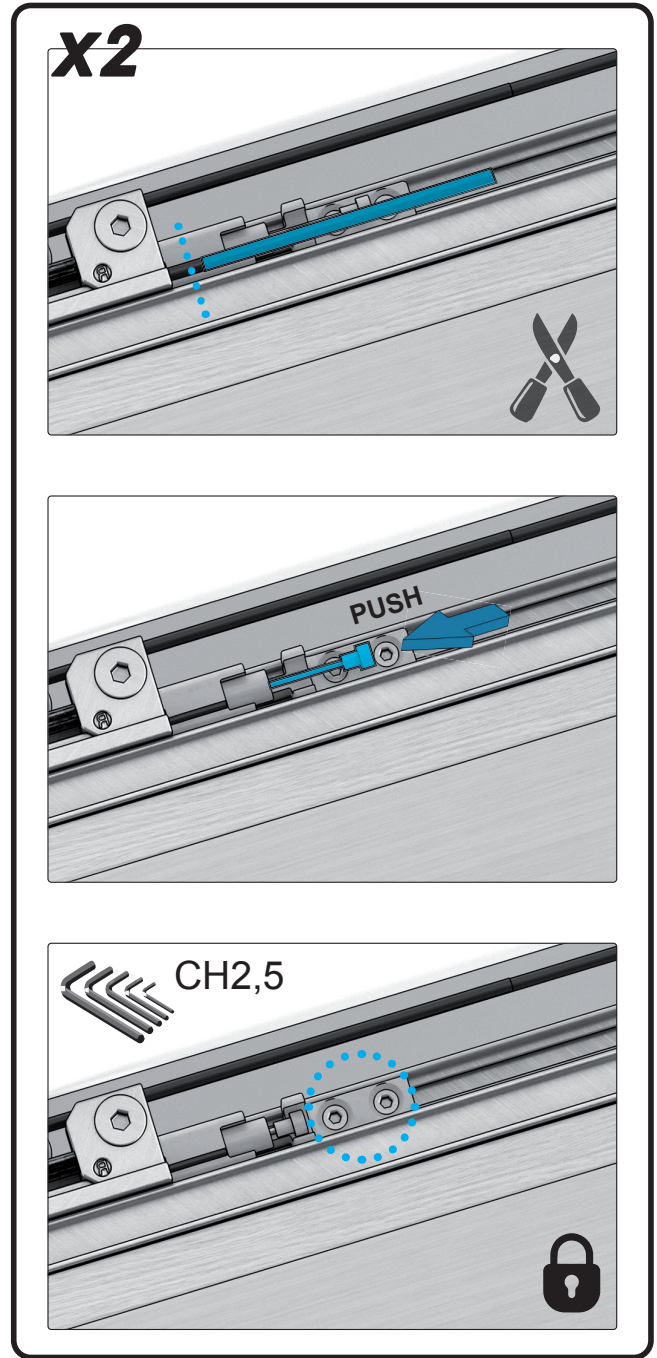



## 6.4

- ⓘ Agire sulle viti per dosare l'effetto "antisbandamento"
- Ⓔ Actúe sobre los tornillos para dosificar el efecto "antideslizante"
- Ⓓ Die Schraube drehen um die „Kippsicherung“ einzustellen
- ⒼⒷ Use the screws to measure the skid control effect
- Ⓕ Agir sur les vis pour régler et ajuster l'effet anti-dérapant
- ⓇⓊⓈ Зафиксировать винты, чтобы избежать колебаний

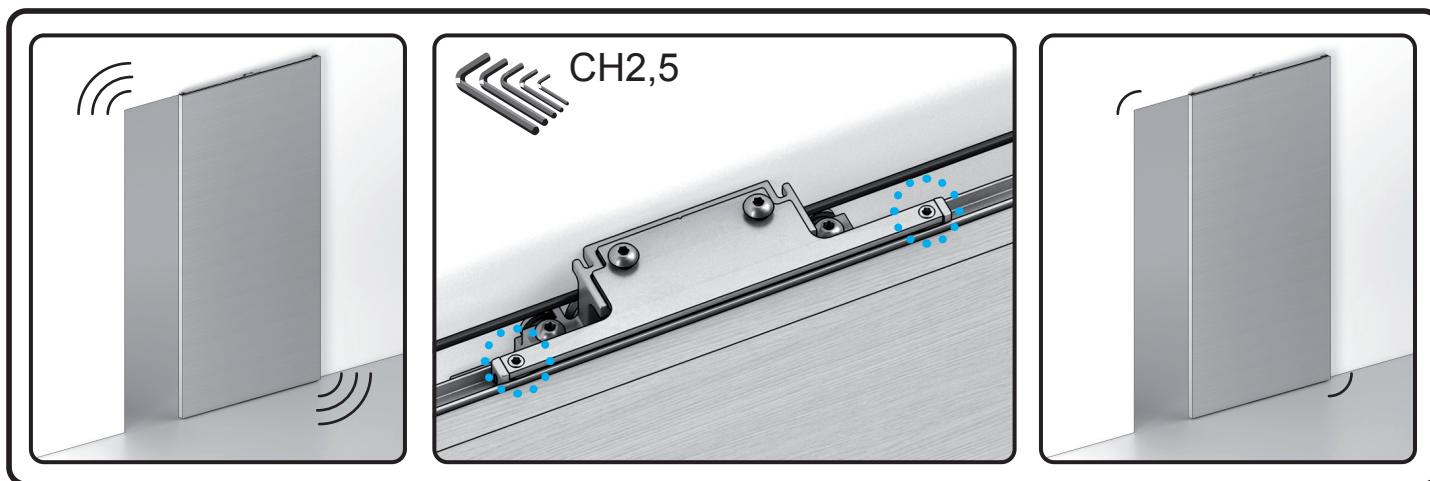

- ⓘ Installazione completata
- Ⓔ Instalación completa
- Ⓓ Montage vollendet
- ⒼⒷ Installation completed
- Ⓕ Installation complète
- ⓇⓊⓈ Установка завершена

**I Lavorazioni pannello con tappi** **E Panel de procesamiento con tapas** **D Türblattverarbeitung mit Abdeckkappen**  
**GB Door preparation with caps** **F Usinage du panneau avec des bouchons** **RUS Установка полотна с заглушками**

lato esterno - lado exterior - Außenseite - external side - côté extérieur - внешняя сторона

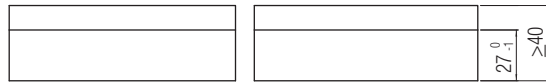

lato parete - lado pared - Wandseite - wall side - côté mur - сторона стены

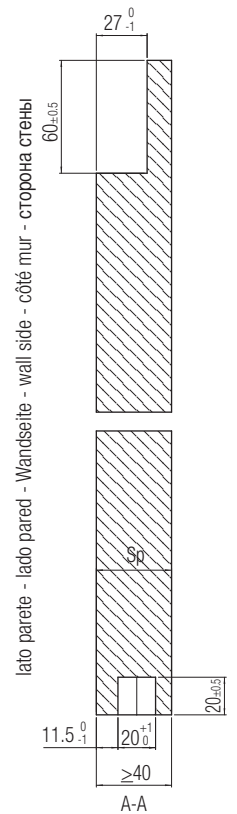
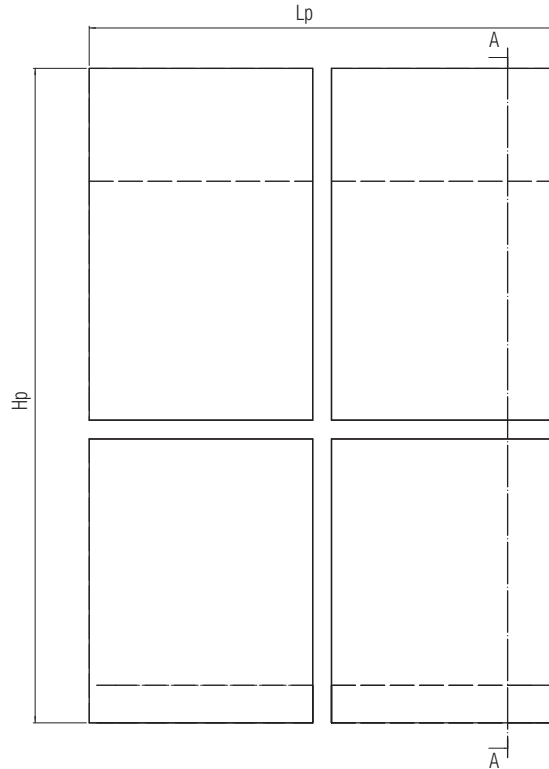
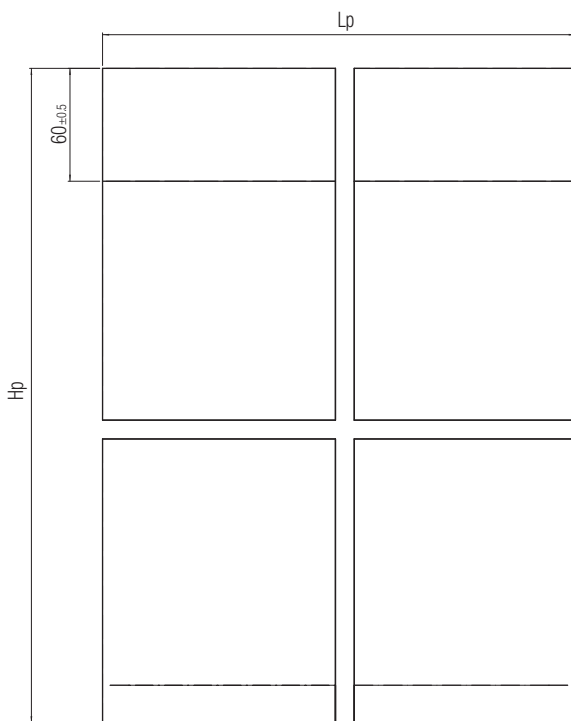

lato parete - lado pared - Wandseite - wall side - côté mur - сторона стены

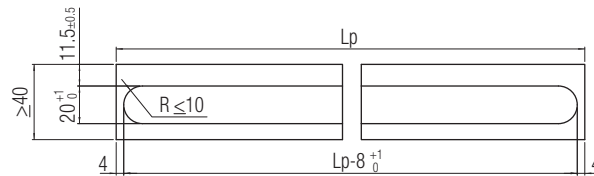

lato esterno - lado exterior - Außenseite - external side - côté extérieur - внешняя сторона

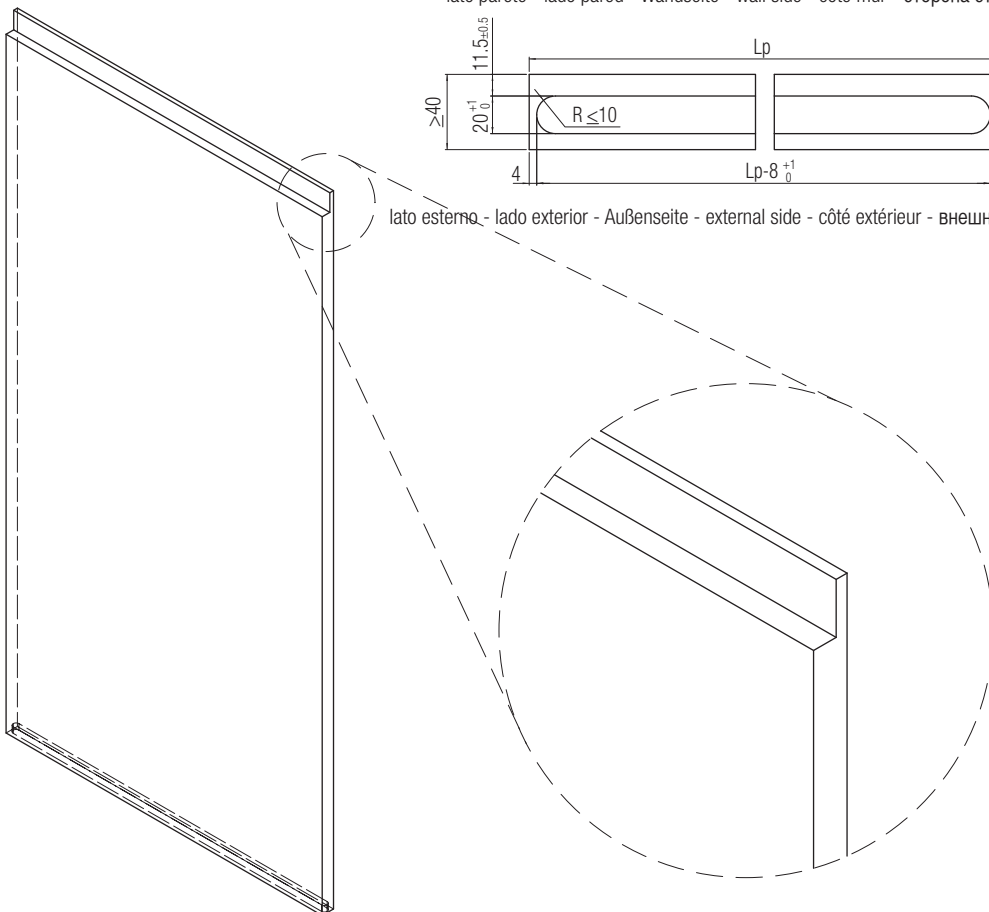

**I** Lavorazioni pannello senza tappi **E** Panel de procesamiento sin tapa **D** Türblattverarbeitung ohne Abdeckkappen  
**GB** Door preparation without caps **F** Usinage du panneau sans bouchons **RUS** Установка полотна без заглушек

lato esterno - lado exterior - Außenseite - external side - côté extérieur - внешняя сторона

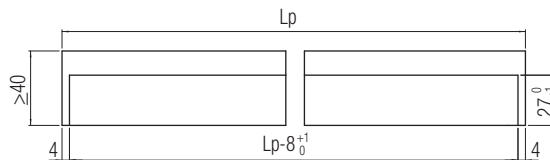

lato parete - lado pared - Wandseite - wall side - côté mur - сторона стены

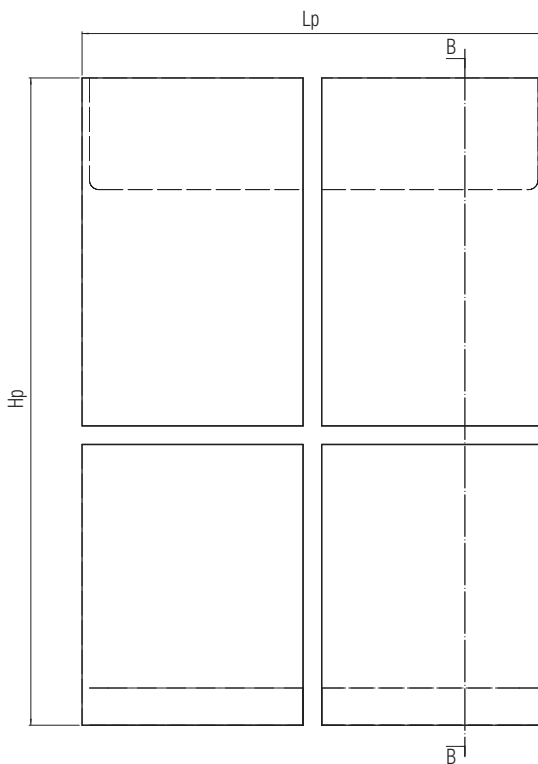
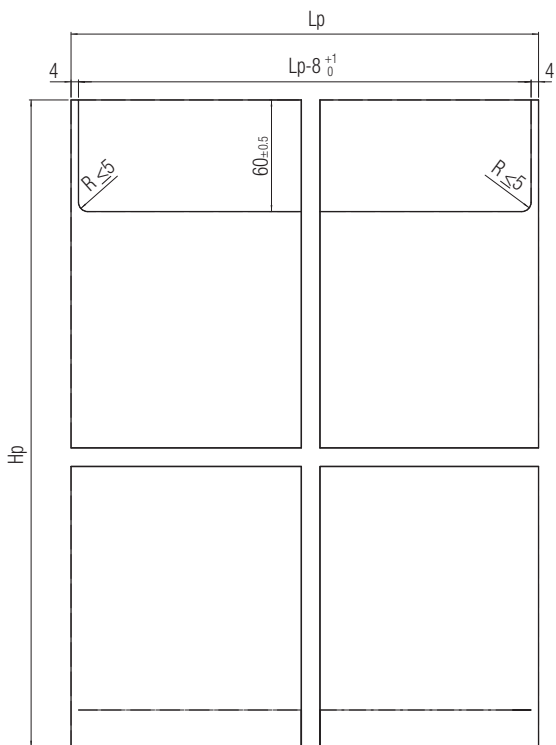

lato parete - lado pared - Wandseite - wall side - côté mur - сторона стены

lato esterno - lado exterior - Außenseite - external side - côté extérieur - внешняя сторона

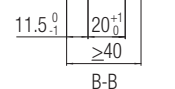

lato parete - lado pared - Wandseite - wall side - côté mur - сторона стены

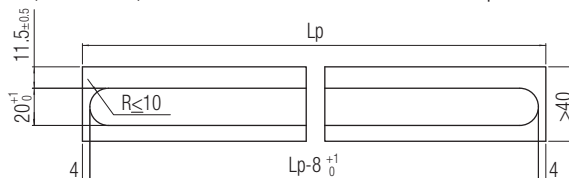

lato esterno - lado exterior - Außenseite - external side - côté extérieur - внешняя сторона

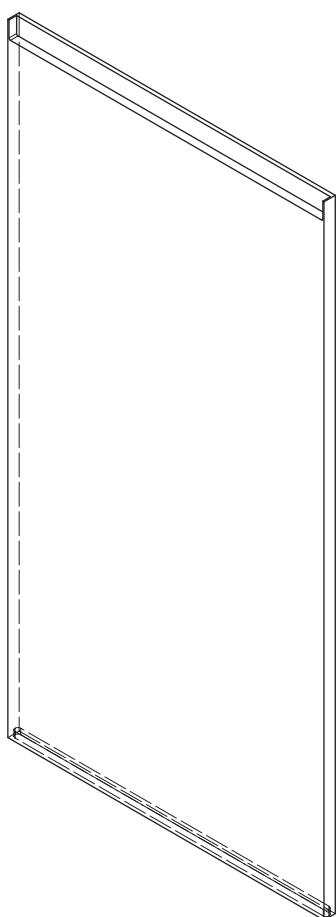

- I** Lavorazione pannello inferiore per installazione in nicchia o su mobile.  
**E** Procesamiento de panel inferior para la instalacion en muebles.  
**D** Untere Türblattverarbeitung für Nischen- oder Möbelmontage.  
**GB** Preparation of the lower side of the door for installing it into the recess or furniture.  
**F** Usinage du panneau inférieur pour une installation en niche ou sur mobilier.  
**RUS** Обработка низа панели при установке в нишу или на шкаф.

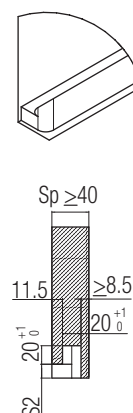
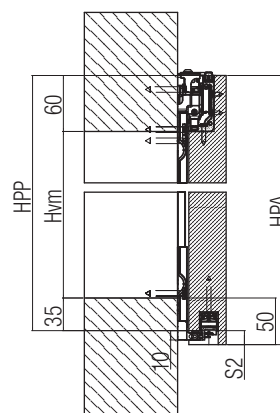



I Taglio profili alluminio E Corte perfil aluminio D Schienen-Zuschnitt

GB Aluminium profiles cutting F Découpe de profil en aluminium RUS Обработка алюминиевого трека

- I Binario superiore
- E Guia superior
- D Obere Schiene
- GB Upper track
- F Rail Supérieur
- RUS Верхний трек

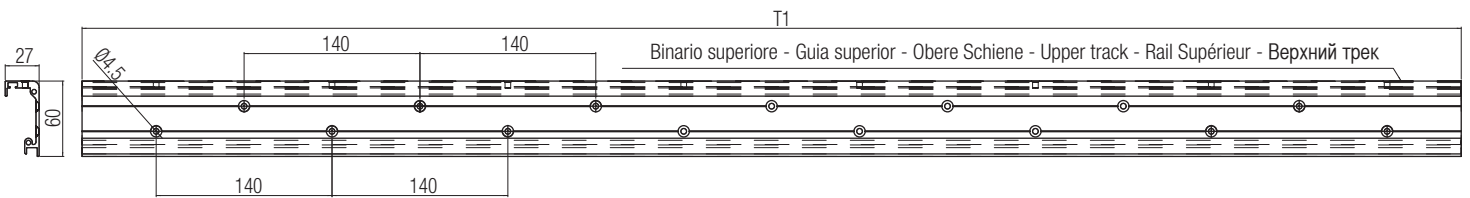
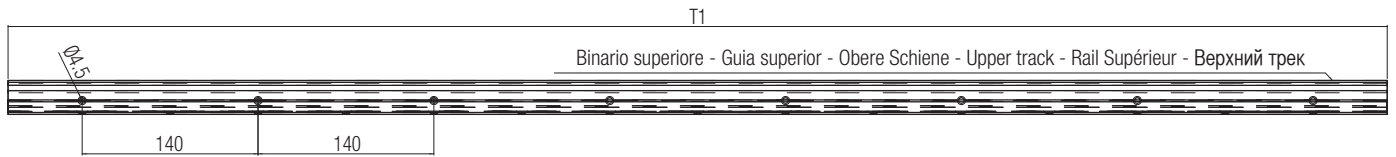
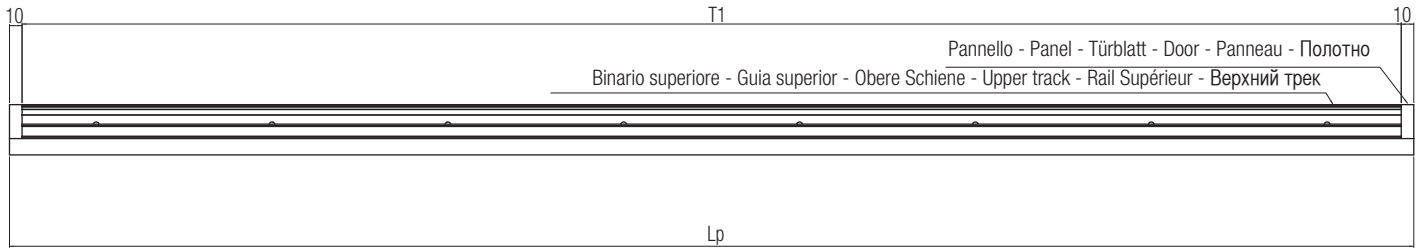

- I Binario inferiore
- E Guia inferior
- D Untere Schiene
- GB Lower track
- F Rail inférieur
- RUS Нижний трек

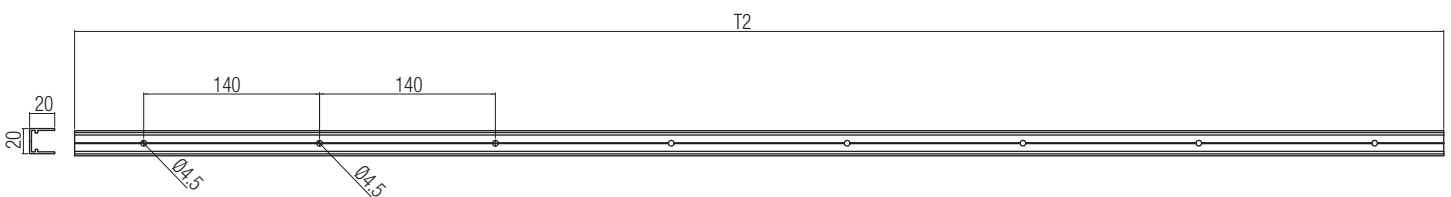
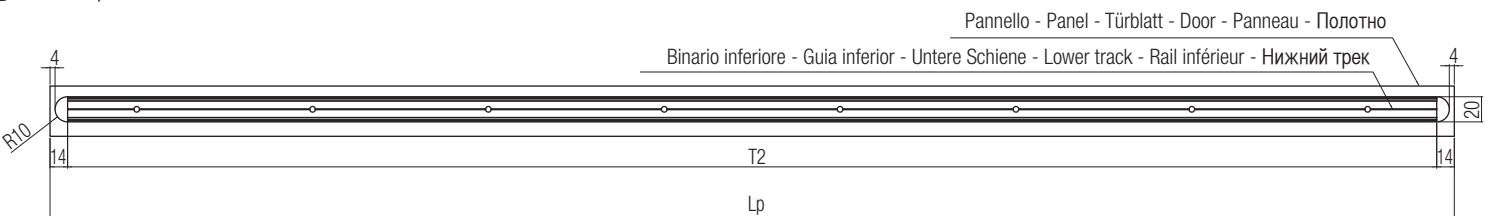

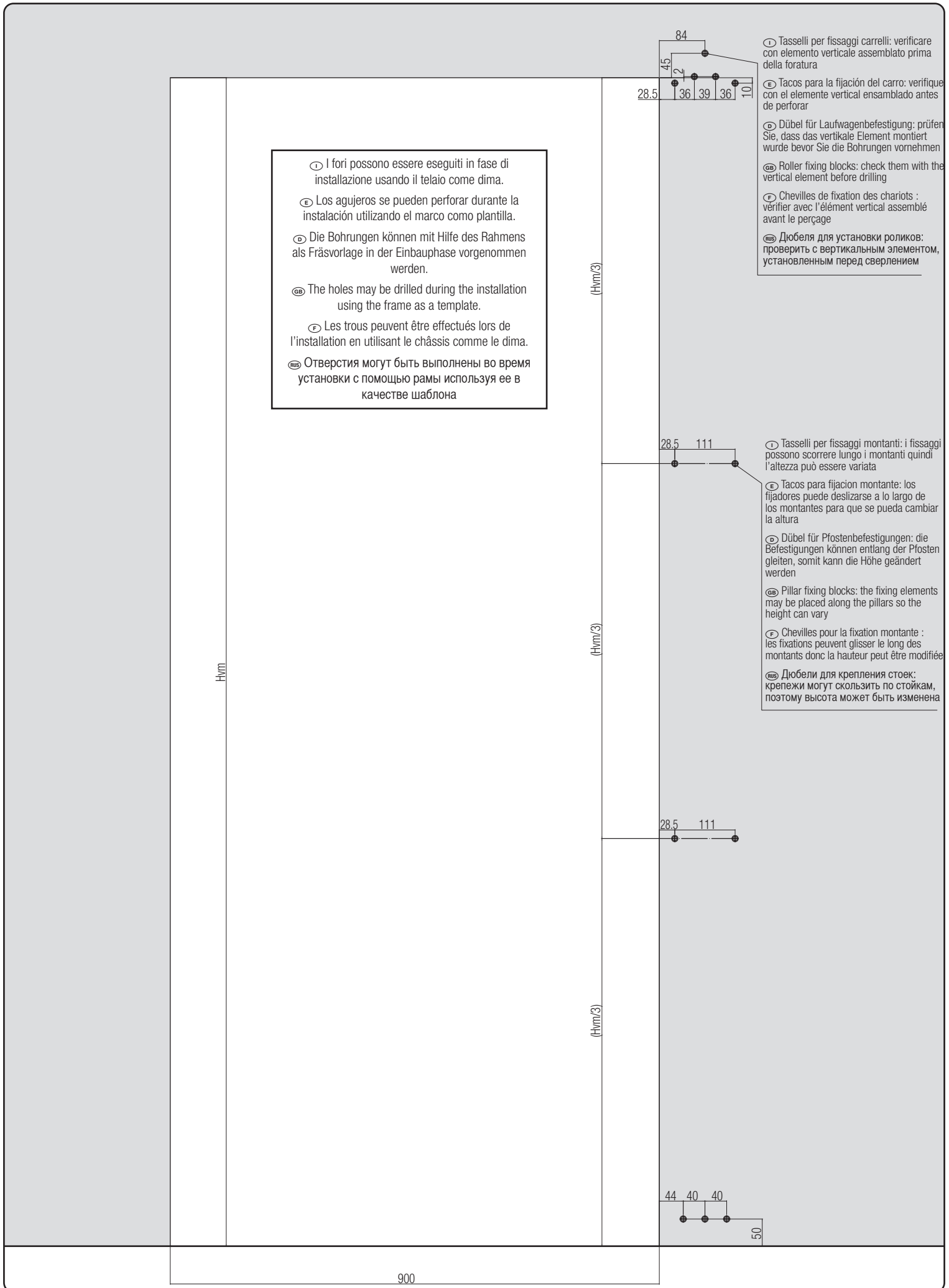

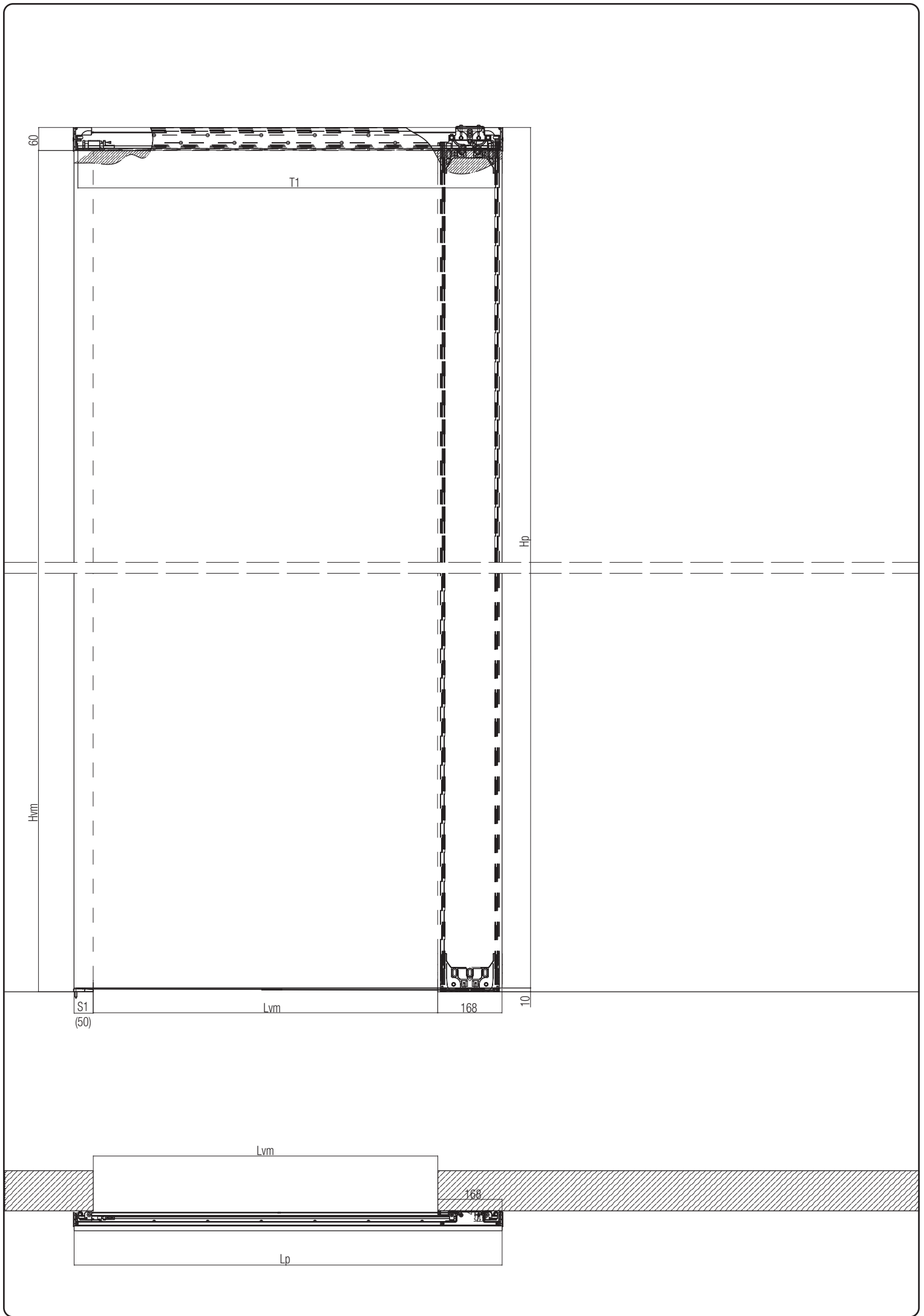



pistoncini finecorsa regolabili - Pistones de final de carrera ajustables - Einstellbare Endstopper  
adjustable limit pistons - pistons de fin de course réglables - регулируемый поршневой ограничитель

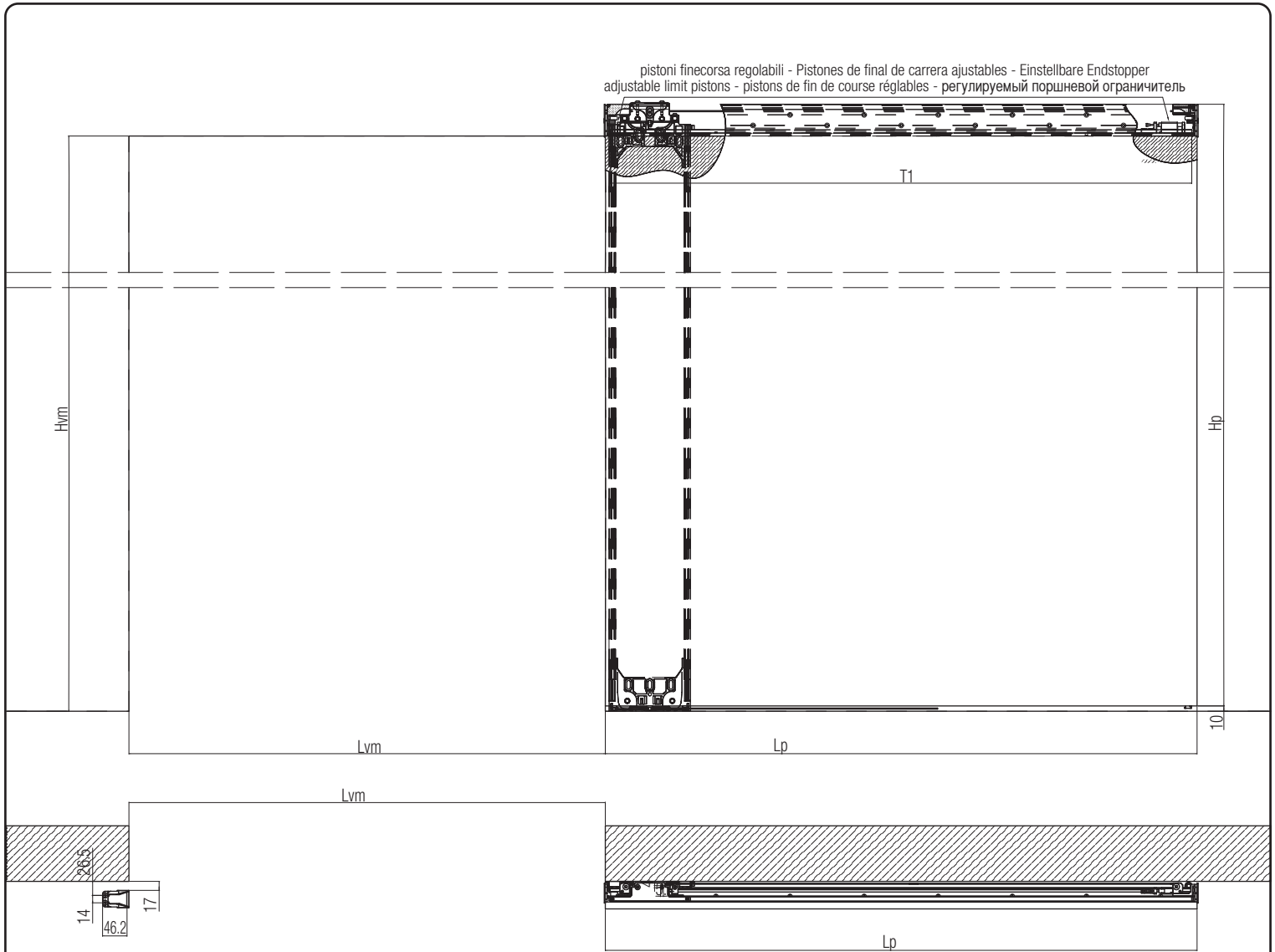

- ① Distanza pannello/parete = 12 mm - Battiscopa spess. max 10 mm - Sp >40
- ② Distancia del panel/ pared = 12mm - Zócalo espesor máximo 10 - Sp >40
- ③ Abstand Türblatt/Wand = 12 mm - Fußbodenleiste maximale Stärke 10 mm - Sp >40
- ④ Door/wall distance = 12 mm - Baseboard thickness max 10 mm - Sp >40
- ⑤ Distance panneau/mur = 12 mm - Épaisseur max de la plinthe 10 mm - Sp >40
- ⑥ Расстояние панель/стена=12мм - Толщина плинтуса макс.=10 - Sp >40

⑦ DATI DI PARTENZA:

Lvm = Larghezza vano muro  
Hvm = Altezza vano muro  
DIMENSIONI PANNELLO STANDARD:  
Lp = Larghezza pannello = Lvm + 218 mm  
Hp = Altezza pannello = Hvm + 50 mm  
Sp = Spessore pannello  
S1 = Sporgenza porta per maniglia esterna  
S2 = Sporgenza anteriore pannello armadio  
LUNGHEZZE ESTRUSI:  
T1 = Lunghezza di taglio binario superiore = Lp - 20 mm  
T2 = Lunghezza di taglio binario inferiore = Lp - 28 mm  
T3 = Lunghezza di taglio montante verticale = Hp - 130 mm

⑧ Daten:

Lvm = Maueröffnungsbreite  
Hvm = Maueröffnungshöhe  
Türblatt Standard-Ausmaß:  
Lp = Türblattbreite = Lvm + 218 mm  
Hp = Türblatthöhe = Hvm + 50 mm  
Sp = Türblattstärke  
S1 = Überstand für Türen mit Türgriff  
S2 = hinterer Überstand Türblatt Schrank  
Länge der Profile:  
T1 = Schnittlänge obere Laufschiene = Lp - 20 mm  
T2 = Schnittlänge untere Laufschiene = Lp - 28 mm  
T3 = Schnittlänge vertikaler Pfosten = Hp - 130 mm

⑨ DONNÉES DE DÉPART:

Lvm = Largeur de passage total du compartiment du mur  
Hvm = Hauteur de passage total du compartiment du mur  
TAILLE DE PANNEAU STANDARD:  
Lp = Largeur du panneau = Lvm + 218 mm  
Hp = Hauteur du panneau = Hvm + 50 mm  
Sp = Épaisseur du panneau  
S1 = Réserve de la porte pour poignée extérieure  
S2 = Réserve avant du panneau de l'armoire  
LONGUEURS EXTRUDES:  
T1 = Longueur de coupe du rail supérieure = Lp - 20 mm  
T2 = Longueur de coupe du rail inférieure = Lp - 28 mm  
T3 = Longueur de coupe du montant vertical = Hp - 130 mm

⑩ DATOS DE SALIDA:

Lvm = Ancho del compartimento de la pared  
Hvm = Altura del compartimento de la pared  
DIMENSIONES DEL PANEL ESTÁNDAR:  
Lp = Ancho del panel = Lvm + 218 mm  
Hp = Altura del panel = Hvm + 50 mm  
Sp = Grosor del panel  
S1 = Extensión de puerta para manija externa  
S2 = Saliente del armario del panel frontal  
LONGITUDES EASTRUSED:  
T1 = Longitud de corte de la vía superior = Lp - 20 mm  
T2 = Longitud de corte de vía inferior = Lp - 28 mm  
T3 = Longitud de corte vertical vertical = Hp - 130 mm

⑪ INITIAL DATA:

Lvm = Wall opening width  
Hvm = Wall opening height  
STANDARD DOOR DIMENSIONS:  
Lp = Door width = Lvm + 218 mm  
Hp = Door height = Hvm + 50 mm  
Sp = Door thickness  
S1 = Door protrusion due to the external handle  
S2 = Front protrusion of the cabinet door  
LENGTHS:  
T1 = Upper track length to cut = Lp - 20 mm  
T2 = Lower track length to cut = Lp - 28 mm  
T3 = Vertical pillar length to cut = Hp - 130 mm

⑫ ИСХОДНЫЕ ДАННЫЕ:

Lvm = Ширина прохода  
Hvm = Высота прохода  
СТАНДАРТНЫЕ РАЗМЕРЫ ПОЛОТНА  
Lp = Ширина полотна = Lvm+218мм  
Hp = Высота полотна = Hvm+50мм  
Sp = Толщина полотна  
S1 = Выступ двери для внешней ручки  
S2 = Передний выступ панели шкафа  
ДЛИНЫ:  
T1 = Длина верхней направляющей = Lp-20мм  
T2 = Длина нижнего трека = Lp-28мм  
T3 = Длина резки вертикальных направляющих = Hp-130мм

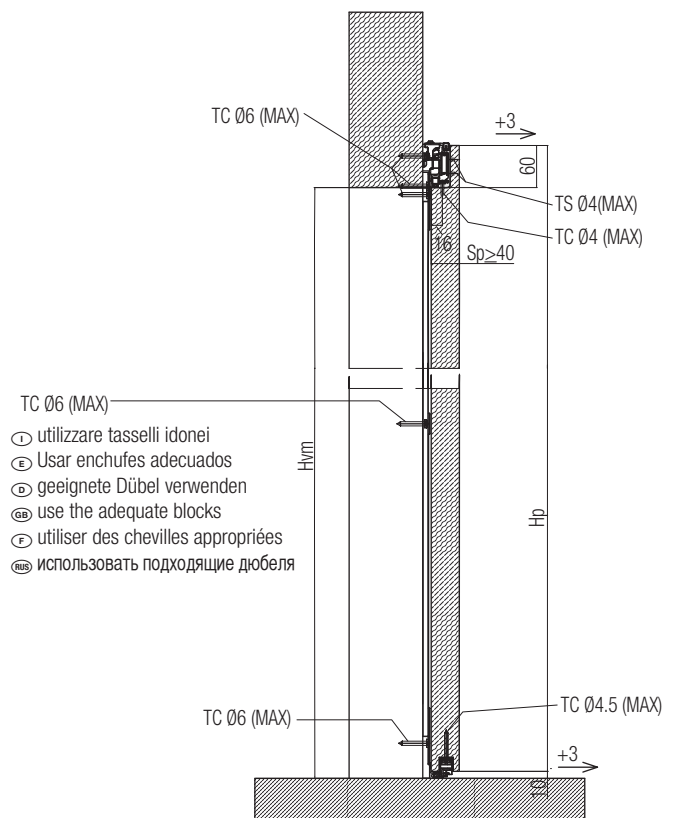

- ⑬ utilizzare tasselli idonei
- ⑭ Usar enchufes adecuados
- ⑮ geeignete Dübel verwenden
- ⑯ use the adequate blocks
- ⑰ utiliser des chevilles appropriées
- ⑱ использовать подходящие дюбеля

## OPTIONAL

- ① Guida di sicurezza: per evitare un'apertura/chiusura scorretta della porta.
- ② Guía de seguridad: para evitar la apertura/cierre incorrecto de la puerta.
- ③ Sicherungsführung: um eine unkorrekte Öffnung/Schließung der Tür zu vermeiden.
- ④ Safety guide: in order to avoid incorrect opening/closing of the door.
- ⑤ Guide de sécurité : pour éviter une ouverture/fermeture incorrecte de la porte.
- ⑥ Предохранительная направляющая: для предотвращения некорректное открывание/закрывание двери.

- ① Battiscopa spessore max = 10 mm
- ② Zócalo espesor máximo = 10 mm
- ③ Fußbodenleiste maximale Stärke = 10 mm
- ④ Baseboard thickness max = 10 mm
- ⑤ Épaisseur max de la plinthe = 10 mm
- ⑥ Толщина плинтуса макс.=10 мм

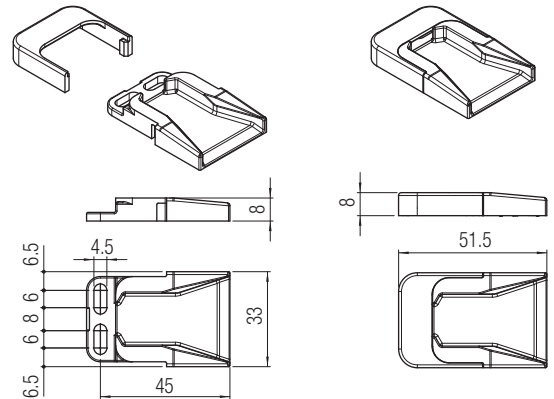
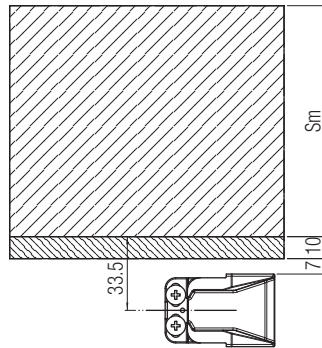

## OPTIONAL

- ① Nottolino di sicurezza: per evitare un'apertura/chiusura scorretta della porta.
- ② Captura de seguridad: para evitar la apertura / cierre incorrecto de la puerta.
- ③ Sicherungsführung: um eine unkorrekte Öffnung/Schließung der Tür zu vermeiden.
- ④ Safety guide: in order to avoid incorrect opening/closing of the door.
- ⑤ Guide de sécurité : pour éviter une ouverture/fermeture incorrecte de la porte.
- ⑥ Предохранительная направляющая: для предотвращения некорректное открывание/закрывание двери.

- ① Battiscopa spessore max = 10 mm
- ② Zócalo espesor máximo = 10 mm
- ③ Fußbodenleiste maximale Stärke = 10 mm
- ④ Baseboard thickness max = 10 mm
- ⑤ Épaisseur max de la plinthe = 10 mm
- ⑥ Толщина плинтуса макс.=10 мм

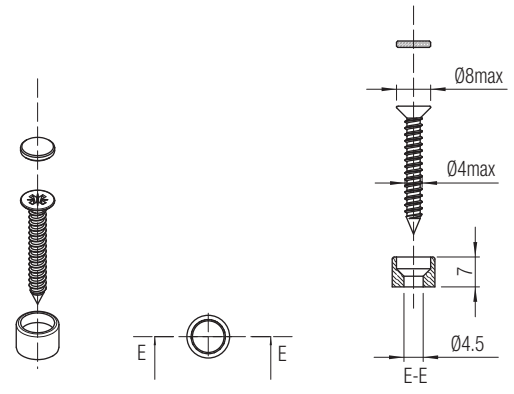
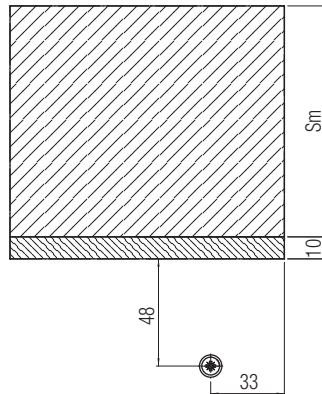

Altezza pannello - Altura panel Türblatthöhe - Door height Hauteur vantail - Высота дверной панели (mm)	TRICKS - 50 Kg								
	1100	700	800	900	1000	1100	1200	1300	1400
2500		50	50	50	50	50	50	49	46
2400		50	50	50	50	50	50	47	44
2200		50	50	50	50	50	47	43	40
2000		50	50	50	50	47	43	39	37
1800		50	50	50	46	42	38	35	33
1600		50	50	45	41	37	34	31	29
1400		50	45	40	36	33	30	28	26
1200		44	38	34	31	28	26	24	22
1000		37	32	28	26	23	21	20	18
2150	50								

(mm)  
Larghezza pannello - Ancho panel - Türblattbreite  
Door width - Largeur vantail - Ширина дверной панели

- ① Installazioni alternative ② Instalaciones alternativas ③ Alternative Verarbeitung
- ④ Installation options ⑤ Installations alternatives ⑥ Альтернативные установки



Ⓘ **Risoluzione dei problemi** Ⓔ **Resolucion de problemas** Ⓓ **Problemlösung**  
ⒼⒸ **Problems and solutions** Ⓕ **Résolutions des problèmes** ⒸⒶ **Решение проблем**

Problem	Possible cause	Possible solution
<span>Ⓘ</span> Il pannello è storto <span>Ⓔ</span> El panel esta trocido <span>Ⓓ</span> Das Türblatt hängt schief <span>ⒼⒸ</span> The door is not straight <span>Ⓕ</span> Le panneau est de travers <span>ⒸⒶ</span> Кривое полотно	<span>Ⓘ</span> Errata regolazione <span>Ⓔ</span> Ajuste incorrecto <span>Ⓓ</span> Falsche Einstellung <span>ⒼⒸ</span> Wrong adjustment <span>Ⓕ</span> Mauvais réglage <span>ⒸⒶ</span> Неправильная установка	<span>Ⓘ</span> Allentare il cavo nello spigolo più alto. Tensionare l'altro cavo compiendo lo stesso numero di giri nella vite <span>Ⓔ</span> Afloje el cable en la esquina más alta. Tense el otro cable haciendo el mismo número de vueltas en el tornillo <span>Ⓓ</span> Lockern Sie das Seil in der obersten Kante. Spannen Sie das andere Seil und mit gleichvielen Umdrehungen der Schraube <span>ⒼⒸ</span> Loosen the cable in the upper corner. Tighten the other cable with the same number of rotations of the screw <span>Ⓕ</span> Desserrer le câble dans l'arête supérieure. Tendre l'autre câble en accomplissant le même nombre de tours de vis <span>ⒸⒶ</span> Расслабить трос в самом верхнем углу. Натянуть другой конец троса, делая такое же количество оборотов в винтах
<span>Ⓘ</span> Vedi fig. 25 <span>Ⓔ</span> Ver fig. 25 <span>Ⓓ</span> Siehe Abb. 25 <span>ⒼⒸ</span> See image 25 <span>Ⓕ</span> Voir fig 25 <span>ⒸⒶ</span> см. пункт. 25		

Problem	Possible cause	Possible solution
<span>Ⓘ</span> Il pannello cala molto ai lati <span>Ⓔ</span> El panel cae mucho hacia los lados <span>Ⓓ</span> Türblatt hängt seitlich <span>ⒼⒸ</span> The door leans a lot on the sides <span>Ⓕ</span> Le panneau descend beaucoup sur les côtés <span>ⒸⒶ</span> Полотно сильно опущено в конечных положениях	<span>Ⓘ</span> Pannello pesante <span>Ⓔ</span> Panel pesado <span>Ⓓ</span> Schweres Türblatt <span>ⒼⒸ</span> Heavy door <span>Ⓕ</span> Panneau lourd <span>ⒸⒶ</span> Тяжелое полотно	<span>Ⓘ</span> Tensionare entrambi i cavi poco alla volta e verificare lo scorrimento <span>Ⓔ</span> Tense ambos cable poco a poco y compruebe el deslizamiento <span>Ⓓ</span> Spannen Sie langsam beide Kabel und prüfen sie das Gleiten der Tür <span>ⒼⒸ</span> Tighten both cables a bit at a time and check the sliding <span>Ⓕ</span> Tendre les deux câbles peu à peu et vérifier le glissement <span>ⒸⒶ</span> Натянуть оба троса и постепенно проверять скольжение
<span>Ⓘ</span> Vedi fig. 25 <span>Ⓔ</span> Ver fig. 25 <span>Ⓓ</span> Siehe Abb. 25 <span>ⒼⒸ</span> See image 25 <span>Ⓕ</span> Voir fig 25 <span>ⒸⒶ</span> см. пункт. 25		

Problem	Possible cause	Possible solution
<span>Ⓘ</span> Il pannello ha problemi di scorrevolezza <span>Ⓔ</span> El panel tiene problema e fluidez <span>Ⓓ</span> Das Türblatt gleitet nicht korrekt <span>ⒼⒸ</span> The door has sliding problems <span>Ⓕ</span> Le panneau a des problèmes de fluidité (mauvais glissement de la porte) <span>ⒸⒶ</span> Полотно плохо скользит	<span>Ⓘ</span> - Cable retorcido - Cable muy apretados - Guía anti-descarrilamiento con tornillos demasiado flojos <span>Ⓔ</span> - Cavi attorcigliati - Cavi troppo tirati - Guida antiscarrucolamento con grani troppo svitati <span>Ⓓ</span> - Seile verdreht - Seile zu gespannt - Abrutschsicherung mit zu wenig angezogenen Gewindestifte <span>ⒼⒸ</span> - Twisted cables - Cables too much tightened - Grub screws of the anti-slip guide are not tight <span>Ⓕ</span> - Câbles torsadés - Des câbles trop serrés - Guide anti-décrochement trop dévissé <span>ⒸⒶ</span> - Скрученные тросы - Тросы слишком натянуты - Антискользящая направляющая с раскрученными винтами	<span>Ⓘ</span> - Compruebe que los cables solo tiene un cruce - Afloje ambos cables por igual - Atornille los 2 grados <span>Ⓔ</span> - Controllare che i cavi abbiano un solo incrocio - Allentare entrambi i cavi in egual modo - Avvitare i 2 grani <span>Ⓓ</span> - Prüfen Sie, dass sich die Seile nur einmal überkreuzten - Lockern Sie beide Seile gleichermaßen - Ziehen Sie die 2 Gewindestifte an <span>ⒼⒸ</span> - Make sure the cables only have one intersection - Loosen both cables equally - Tighten the 2 grub screws <span>Ⓕ</span> - Vérifier qu'il n'y a qu'un seul croisement de cables - Desserrer les deux câbles de manière égale - Visser les deux grains <span>ⒸⒶ</span> - Контролировать, чтобы тросы имели одно пересечение - Расслабить оба троса в обоих случаях - Закрутить 2 винта
<span>Ⓘ</span> Vedi fig. 25 <span>Ⓔ</span> Ver fig. 25 <span>Ⓓ</span> Siehe Abb. 25 <span>ⒼⒸ</span> See image 25 <span>Ⓕ</span> Voir fig 25 <span>ⒸⒶ</span> см. пункт. 25		



Problem	Possible cause	Possible solution
① Il pannello striscia sulla parete ② El panel se tira en la pared ③ Das Türblatt schleift an der Wand ④ The door rubs the wall ⑤ Alignement du panneau sur le mur ⑥ Полотно касается стены	① - Parete irregolare - Viti di blocco non serrate ② - Muro irregular - Tornillos de bloqueo no apretados ③ - Unregelmäßige Wand - Einstellschrauben nicht angezogen ④ - Uneven wall - Blocking screws are not tight ⑤ - Paroie murale irrégulière - Vis de blocage non serrées ⑥ - Неровная стена - Винты блокировки не затянуты	① - Allentare le viti e allontanare il pannello dalla parete, poi serrare le viti - Controllare il serraggio delle 6 viti ② - Afloje los tornillos y aleje el panel de la pared luego apriete los tornillos - Compruebe y aprete los 6 tornillos ③ - Lösen Sie die Schrauben und distanzieren Sie das Türblatt von der Wand, dann ziehen Sie die Schrauben an - Prüfen Sie, dass alle 6 Schrauben angezogen sind ④ - Loosen the screws and take the door away from the wall, then tighten the screws - Check if all 6 screws are tightened ⑤ - Desserrer les vis et éloigner le panneau du mur, puis serrer les vis - Vérifier le serrage des 6 vis ⑥ - Расслабить винты и отодвинуть полотно от стены, затем закрутить винты - Проверить фиксацию 6 винтов

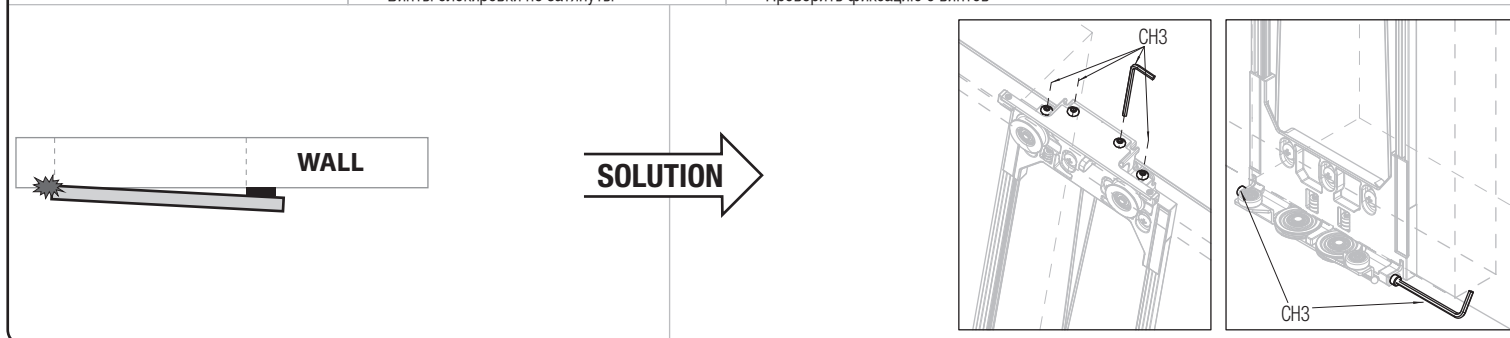

Problem	Possible cause	Possible solution
① Il pannello ha molto gioco ② El panel tiene mucho juego ③ Das Türblatt hat zu viel Spielraum ④ The door has too much play ⑤ Le panneau a beaucoup de jeu ⑥ Полотно Имеет Большой Зазор	① - Viti di blocco non serrate - Guida anticarrucolamento con grani troppo avvitati ② - Tornillo de bloqueo no enroscados - Guía anti-deslizamiento con tornillos demasiado atornillados ③ - Einstellschrauben nicht angezogen - Abrutschsicherung mit zu fest angezogenen Gewindestifte ④ - Blocking screws are not tightened - Grub screws of the anti-slip guide are too tight ⑤ - Vis de blocage non serrées - Guide anti-décrochement trop dévissé ⑥ - Винты блокировки не затянуты - Антискользящая направляющая сильно закрученными винтами	① - Controllare il serraggio delle 6 viti - Svitare i 2 grani ② - Compruebe el enroscado de los 6 tornillos - Desenroscar 2 grados ③ - Prüfen Sie, dass alle 6 Schrauben angezogen sind - Lösen Sie die Gewindestifte ④ - Check the tightening of all 6 screws - Loosen the 2 grub screws ⑤ - Vérifier le serrage des 6 vis - Dévisser les deux grains du guide ⑥ - Проверить фиксацию 6 винтов - Ослабить 2 винта

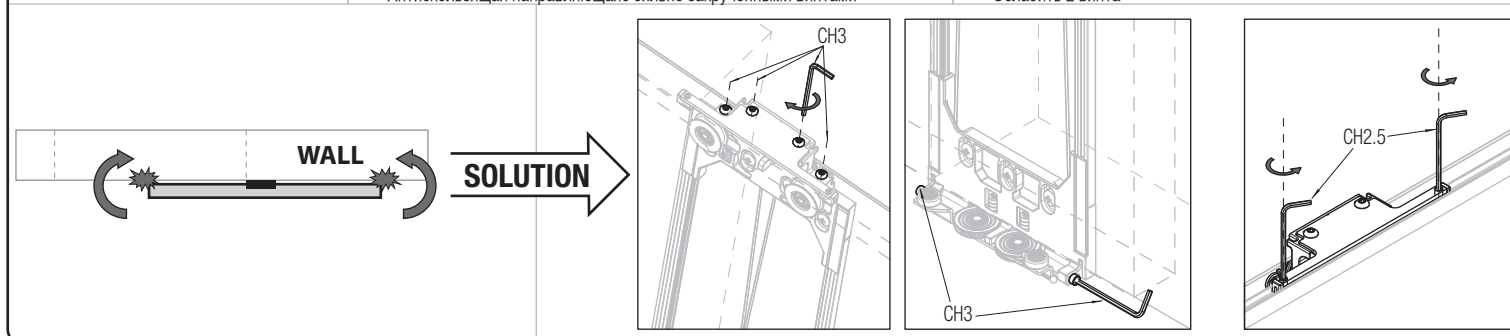



Illustrazioni, fotografie, disegni e dati tecnici, prestazioni, essenze e colori hanno valore puramente indicativo e non sono vincolanti per noi. Deviazioni o scostamenti non potranno costituire ragioni per la non accettazione della merce o essere motivo per reclami. Tutti i modelli possono subire senza preavviso variazioni nelle sezioni, nella struttura e nel disegno.

Ilustraciones, fotografías, diseño y datos técnicos, prestaciones, esencias y colores son valores puramente indicativos y no son vinculantes para nosotros. Las "modificaciones" no son razón para la no aceptación de los productos o ser motivo de quejas. Todos los modelos pueden estar sujetos a cambios sin previo aviso en las secciones, en la estructura y en el diseño.

Abbildungen, Fotos, Zeichnungen und technische Daten, Farben und Farbenszenen die in diesem Katalog angeführt werden sind rein indikativ und für uns unverbindlich. Änderungen und Abweichungen davon werden nicht als Grund für Nichtentgegennahme der Ware oder für Reklamationen akzeptiert. Alle Modelle können unangekündigt Verbesserungen oder leichte Änderungen und den Sektionen und Zeichnungen erfahren.

The illustrations, photos, images and technical data, features and colours of the catalogue are purely indicative and are not binding for us. The deviations cannot create any reasons for not accepting the goods or cause claims. All the models can be altered, improved or slightly modified in their sections, structure or drawing without any previous notification.

Les illustrations, les photographies, les dessins et les données techniques, les prestations, les couleurs reportées sur ce catalogue ont une simple valeur indicative et ne sont pas astreignants pour nous. Des interprétations ou des jugements personnels ne pourront pas constituer une raison pour la non acceptation de la marchandise ou même être un motif de réclamation. Tous les modèles présentés peuvent subir sans préavis une amélioration ou une légère variation dans les sections, dans la structure ou même dans le dessin.

De illustraties, foto's, afbeeldingen en technische gegevens, kenmerken en kleuren van de catalogus zijn louter indicatief en niet bindend voor ons. Afwijkingen kunnen geen reden zijn om de goederen niet te accepteren of claims in te stellen. Alle modellen kunnen zonder voorafgaande kennisgeving worden gewijzigd, verbeterd of licht gewijzigd in hun secties, structuur of tekening.

Иллюстрации, фотографии, рисунки и технические данные в данном справочнике несут рекомендательный характер, которые не могут быть основанием для отказа от товара или стать причиной рекламации. Все артикулы и чертежи могут быть изменены без предварительного согласования с покупателем.



[www.kronakoblenz.com](http://www.kronakoblenz.com)

- ① Via Piane, 90 - 47853 Coriano (RN) - ITALY - Tel. +39 0541 657040 - Fax +39 0541 658211
- ② P.I. MOLI D'EN XEC NAVE n P3-3/6 \_ c/ Moli d' en Xec, n 49/55 C.P. 08291 Ripollet - (Barcelona) - ESPAÑA - Tel: +34 93 591 0410 - Fax: +34 93 591 0498
- ③ Saint Georges De Reneins (69830) - 635 Boulevard Napoléon Bullukian - FRANCE - Tel : +33-474090939 - Fax : +33-474090932
- ④ 109052, г. Москва, ул. Нижегородская, д. 50 - РОССИЯ - Тел/факс +7 (495) 532-74-32
- ⑤ KOBLENZ UTTURKAR FITTINGS PRIVATE LIMITED - FLAT No. 3, 1875, Sadashiv Peth, Shree Balaji Prasad Society, Pune - 411030, Maharashtra, INDIA, Ph: +91 020 24540000